

ACCESSORIES

CLAMPS



①
(Standard)



②
(Heavy Duty)

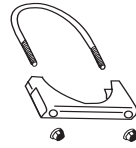

③
(Heavy Duty w/
Welded Saddle)



④
(Guillotine)

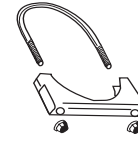

⑤
(Flat Strap U-Bolt)

Size	① STANDARD DUTY CLAMP		② HEAVY DUTY CLAMP		③ HEAVY DUTY CLAMP W/WELDED SADDLE	④ GUILLOTINE CLAMP		⑤ FLAT STRAP U-BOLT CLAMP	
	5/16" U Bolt 13 Gauge Saddle		3/8" U Bolt - 11 Gauge Saddle		3/8" U Bolt - 11 Gauge Saddle	Non Chrome	Chrome	Non Chrome	Chrome
	(50) Indiv. Pkg.	(50) Bulk Pkg.	(50) Indiv. Pkg.	(50) Bulk Pkg.	(50) Indiv. Part	(50) Indiv. Part	Indiv. Part	Indiv. Part	Indiv. Part
1 1/8	35322	—	—	—	—	—	—	—	—
1 1/4	35323	—	—	—	—	—	—	—	—
1 3/8	35324	—	—	—	—	—	—	—	—
1 1/2	35325	34112	—	33112	—	—	—	—	—
1 5/8	35405	34158	—	—	—	—	—	—	—
1 3/4	35406	34134	35343	33134	—	—	—	—	—
1 7/8	35407	34178	35344	33178	—	—	—	—	—
2	35408	34200	35335	33200	—	36145	—	—	—
2 1/8	35334	34218	35364	—	—	—	—	—	—
2 1/4	35413	34214	35336	33214	—	—	—	—	—
2 1/2	35414	34212	35337 35354▲	33212	36248+	35304	—	—	—
2 3/4	—	—	35793	—	—	36147	—	—	—
3	—	—	35794	33300	36249+	35786	—	35624	35444
3 1/4	—	—	—	—	35760	35445	—	—	—
3 1/2	—	—	35753	—	35773	35787	—	35696*	35694*
3 3/4	—	—	—	—	—	—	—	—	—
4	—	—	35752+	33304†+	35774	35788+	35456	35799*	35776
4 7/16	—	—	—	—	35758	35410	—	—	—
4 1/2	—	—	35424	—	—	35373	—	—	—
5	—	—	35775▲+	33305†+	35757	35789+	35457	35800*	35777
5 1/2	—	—	—	—	—	35447*	—	35446	—
6	—	—	—	—	35795	35409	35497	35693*	35692*

▲ Longer U Bolt. † Order in quantities of 25, standard carton. * Order in quantities of 10, standard carton. + Zinc Plated.



Heavy Duty
Slotted



Stainless Steel
U-Clamps

Size	HEAVY DUTY§ w/Slotted U-Bolt Holes 11 Gauge Saddle 3/8" U-Bolt	STAINLESS STEEL U-CLAMPS† T-304 Stainless Steel 11 Gauge Saddle 3/8" U-Bolt	Size
	1 1/2"	32112	
1 5/8"	—	—	1 5/8"
1 3/4"	32134	32215	1 3/4"
1 7/8"	32178	—	1 7/8"
2"	32200	32216	2"
2 1/8"	—	—	2 1/8"
2 1/4"	32214	32217	2 1/4"
2 1/2"	32212	32218	2 1/2"
3"	32300	32219	3"

§ 50 per carton.

† 10 per carton.

AccuSeal™

Narrow Band One Bolt Clamp



Size	Aluminized Steel Part No.	430 Bright Stainless Steel Part No.
2 1/4"	36433	36437
2 1/2"	36434	36438
3"	36435	36439
3 1/2"	36436	36440
4"	35227	36441
5"	35228	36442

10 per Std. carton

TM AccuSeal is a registered trademark of Torca, Auburn Hills, Mi.

Heavy Duty 1/4" Wire Ring Clamp Zinc Plated

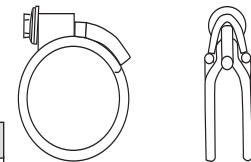

Size Range	Part No.
2 5/16" to 2 1/2"	35723
2 7/16" to 2 5/8"	35731
2 9/16" to 2 3/4"	35510
3 5/16" to 3 1/2"	35279

ACCESSORIES

BAND CLAMPS

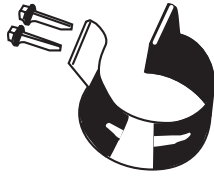

LAP JOINT
Connects OD to ID Pipes

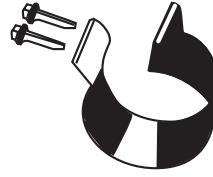

BUTT JOINT
Connects OD to OD or ID to ID Pipes

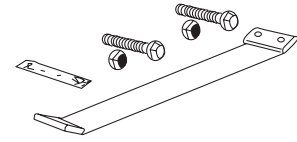

Size	Walker MEGA Clamps		Size
	Aluminized	Stainless	
2	33974	33230	2
2 ¹ / ₄	33975	33231	2 ¹ / ₄
2 ¹ / ₂	33976	33226	2 ¹ / ₂
2 ³ / ₄	33977	33227	2 ³ / ₄
3	33284	33272	3
3 ¹ / ₂	33285	33273	3 ¹ / ₂
4	33286	33274	4
4	33319*	33260*	4
4 ¹ / ₂	33287	33275	4 ¹ / ₂
5	33288	33276	5
5	33321*	33262*	5
6	33289	33277	6

Size	Walker MEGA Clamps		Size
	Aluminized	Stainless	
2	33978	33228	2
2 ¹ / ₄	33979	33229	2 ¹ / ₄
2 ¹ / ₂	36148	33240	2 ¹ / ₂
2 ³ / ₄	36149	33241	2 ³ / ₄
3	33310	33278	3
3 ¹ / ₂	33311	33279	3 ¹ / ₂
4	33312	33280	4
4 ¹ / ₂	33313	33281	4 ¹ / ₂
5	33314	33282	5
6	33315	33283	6

SEAL CLAMP® FLAT BAND CLAMPS		
Size	Aluminized	Stainless
3	—	35934
3 ¹ / ₂	35291	35936
4	35292	35937
5	35293	35938
6	—	35939

Seal Clamp® is a registered trademark of the Donaldson Company.

* Packaged Bulk 10 per carton.

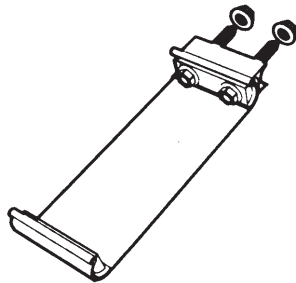

ValuSeal®	
Size	300 Series Stainless
4	36419
5	36420

ValuSeal® is a registered trademark of Torca.

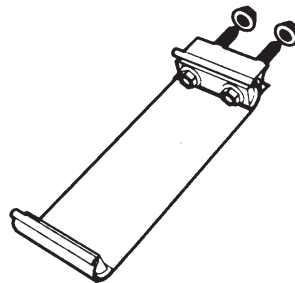

EASY SEAL®	
Size	Stainless
2	35620
2 ¹ / ₄	35621
2 ¹ / ₂	35979
2 ³ / ₄	35622
3	35978
3 ¹ / ₄	35415
3 ¹ / ₂	35977
3 ³ / ₄	35416
4	35976
4 ¹ / ₂	35423
5	35975
6	35980

Easy Seal® is a registered trademark of Torca.

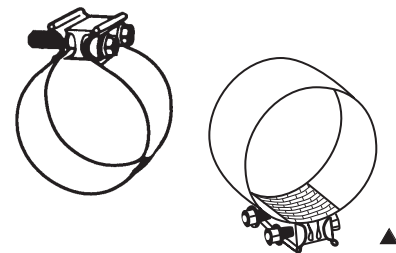

TORCTITE® PREFORMED CLAMPS		
Size	Aluminized Lap Joint	Stainless Lap Joint
2 ¹ / ₂	—	33220
3	33967	33222
3 ¹ / ₄	—	—
3 ¹ / ₂	33968	33223
3 ³ / ₄	—	—
4	33969	33224
4	33980▲	33981▲
5	33970	33225
5	33982▲	33983▲
6	—	33271

▲ With Fiberglass Gasket.

INFORMATION & BUILD TO ORDER

TOOLS AND ACCESSORIES

SCHOOL BUS

MEDIUM DUTY TRUCK GYW 3-6

HEAVY DUTY TRUCK GVV 7-8

APPLICATION BY ENGINE

NOISE AND BACKPRESSURE DATA

TRACTOR

MUFFLER SPECS

O.E. CROSS INDEX

ACCESSORIES

V BAND CLAMPS

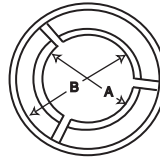
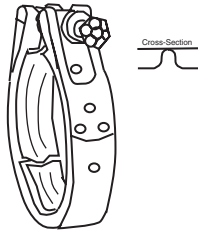

Manufacturer	Part	Dia.	A	Tube B	C	Application
	35449	3.13	3.40	3.96	0.21	Fits - OEM Mufflers
	35805	4.00	4.25	4.81	0.21	Fits - Flared Connectors.
	35500	5.00	5.25	5.81	0.21	Fits - Flared Connectors.
Airesearch	35449	3.00	3.40	3.96	0.21	Replaces #154977
	35449	3.00	3.40	3.96	0.21	4LF-TE0699
	35500	5.00	5.25	5.81	0.21	T-1899, TH08A64
Bluebird	35636	2.75	2.92	3.20	0.26	Replaces Bluebird #1334226
	35636	2.75	2.92	3.20	0.26	1994-88 Bluebird TC2000 School Bus w/5.9L
	35131	4.00	4.12	4.69	0.40	Replaces Bluebird #1250646
	35131	4.00	4.12	4.69	0.40	Bluebird All American w/Cat 3116 /Turbo
	35805	4.00	4.25	4.81	0.21	Replaces Bluebird #0997791
	35805	4.00	4.25	4.81	0.21	1990-80 Bluebird School Bus w/8.2LT
Caterpillar	35520	3.50	3.63	4.19	0.40	3208T
	35804	3.50	3.94	4.50	0.21	3208T
	35131	4.00	4.12	4.69	0.40	3208T
	35036	4.25	4.12	4.81	0.40	3176T
	35290	4.00	4.19	4.75	0.40	3176T
	35806	5.00	5.32	5.88	0.40	3406, 3406B, 3176
Cummins	35636	2.75	2.92	3.20	0.26	6BT5.9L, 6BTA5.9L
	35690	3.00	3.32	3.88	0.40	V555, V902, V903
	35496	3.50	3.69	4.25	0.40	VT555, VT-555 Manifold
	35804	3.50	3.94	4.50	0.21	VT555
	35036	4.25	4.12	4.81	0.40	L10
	35290	4.00	4.19	4.75	0.40	L10
	35806	5.00	5.32	5.88	0.40	750, N, 88NT, NTC, VT
Detroit Diesel	35695	3.00	3.26	3.82	0.21	6V53, 6V71
	36225	2.75	3.82	4.10	0.26	
	35495	3.00	3.47	4.06	0.24	
	35494	3.50	3.75	4.31	0.21	Unknown
	35804	3.50	3.94	4.50	0.21	4-53, 8V71, 8V92
	35499	4.00	4.12	4.75	0.16	8.2LT
	35805	4.00	4.25	4.81	0.21	6-71T, 8.2N, 8.2T, 12V71
	35641	4.00	4.32	4.91	0.29	6-71N
	35746	4.00	4.97	5.25	0.26	8V-71T, 16V-71, 6V-92T, 8V-92, 8V-92T, 16V-92T
	35500	5.00	5.25	5.81	0.21	8V-71T
	35806	5.00	5.25	5.88	0.40	Series 60, 6-71T
	36213	5.00	5.33	5.92	0.29	8V-71T (End away from Turbo)
Ford	36210	2.50	3.26	3.90	0.40	Ford # E5HZ5A231B
	35636	2.75	2.92	3.20	0.26	1995-93 B600/700 w/5.9LT
	35636	2.75	2.92	3.20	0.26	Replaces Ford #F3HZ5A281A
	36225	2.75	3.82	4.10	0.26	Ford #E0HZ5A231B
	35950	3.00	Spec	3.62	0.29	Replaces Ford #F1HZ5C210A, E9HZ5A231B
	35950	3.00	Spec	3.62	0.29	1995-89 Med/Truck/Bus w/370, 429 gas
	35695	3.00	3.26	3.82	0.21	All Models w/DD 6V53, 6V71
	35695	3.00	3.26	3.82	0.21	All Models w/Cummins V555, V902
	35401	3.00	3.26	3.88	0.43	Ford D9HT-51210-DA
	35401	3.00	3.26	3.88	0.43	1988-79 Ford Med Truck/Bus w/370, 429 gas
	35495	3.00	3.47	4.06	0.24	8.2L NA
	35520	3.50	3.63	4.19	0.40	Replaces Ford #E2HZ5A231A
	35520	3.50	3.63	4.19	0.40	1990-87 B600/700 School bus CF600/800 w/6.6LT
	35520	3.50	3.63	4.19	0.40	Replaces Ford #E8HZ5A231E
	35496	3.50	3.69	4.25	0.40	1994-87 CF600/800, F600/800 w/7.8LT
	35496	3.50	3.69	4.25	0.40	Replaces Ford #E7HZ5A231C
	35499	4.00	4.12	4.75	0.16	Replaces Ford #E0HZ5A231C
	35805	4.00	4.25	4.81	0.21	All Models w/DD 6-71T, 8.2N, 8.2T, 12V71

ACCESSORIES

V BAND CLAMPS (Cont.)

Manufacturer	Part	Dia.	A	Tube B	C	Application
Freightliner	35806	5.00	5.32	5.88	0.40	FLD Models w/DD Series 60, CAT 3406
	35806	5.00	5.32	5.88	0.40	FLD Models w/Cummins NTC, VT diesel
	35806	5.00	5.32	5.88	0.40	Replaces Freightliner #0114596000
GM	36225	2.75	3.82	4.10	0.26	
	35495	3.00	3.47	4.06	0.24	1990-80 GM Med Truck/Bus w/8.2L NA
	35495	3.00	3.47	4.06	0.24	Replaces GM #2069773
	35036	4.25	4.12	4.81	0.40	Topkick/Kodiak w/6.6L
	35036	4.25	4.12	4.81	0.40	Replaces GM# 15647159
Mack	35805	4.00	4.25	4.81	0.21	All Models w/DD6-71T, 8.2N, 8.2T, 12V71
	35804	3.50	3.94	4.50	0.21	All Models w/DD 4-53, 8V71, 8V92, CAT 3208T
	35804	3.50	3.94	4.50	0.21	All Models w/Cummins VT-555
	35498	4.00	4.17	4.61	0.16	Replaces Mack #48RU2341
	35498	4.00	4.17	4.61	0.16	DM/MR Models
International/ Navistar	35805	4.00	4.25	4.81	0.21	All Models w/DD 6-71T, 8.2N, 8.2T, 12V71
	35806	5.00	5.32	5.88	0.40	Replaces Mack #11ME241
	35695	3.00	3.26	3.82	0.21	Replaces Navistar #425624R91
	36212	3.00	3.28	3.84	0.21	Replaces Navistar #2033978C1
	35496	3.50	3.69	4.25	0.40	1989-86 Series S Truck/Bus w/DT360
	35496	3.50	3.69	4.25	0.40	Replaces Navistar #893944R92
	35496	3.50	3.69	4.25	0.40	Replaces International #3553803C2
	35494	3.50	3.75	4.31	0.21	Replaces Navistar #338614C1
	35494	3.50	3.75	4.31	0.21	1994-88 Series S Truck/Bus w/DT466
	36374	3.50	3.86	4.38	0.19	2001 Int'l Bus 3800 Series w/T444E
	35804	3.50	3.94	4.50	0.21	Replaces Navistar #434252R91
	35804	3.50	3.94	4.50	0.21	All Models w/DD 4-53, 8V71, 8V92, CAT 3208T
	35804	3.50	3.94	4.50	0.21	All Models w/Cummins VT-555
	35290	4.00	4.19	4.75	0.40	Replaces Navistar #893945R92
	35290	4.00	4.19	4.75	0.40	7.3L, DT-DTA 360, DT-DTA 466
	35641	4.00	4.32	4.91	0.29	Replaces Navistar #433192R91
	35641	4.00	4.32	4.91	0.29	All Models w/6-71N
35746	4.00	4.97	5.25	0.26	9300 Series w/DD 8V71, 8V92	
35746	4.00	4.97	5.25	0.26	Replaces Navistar #5132650	
35746	4.00	4.97	5.25	0.26	Replaces Navistar #780067C91	
35806	5.00	5.25	5.88	0.40	2500/2600 Series w/Detroit 6-71T, Series 60, Cat 3406	
35806	5.00	5.25	5.88	0.40	Replaces Navistar #1672105C91	
35806	5.00	5.25	5.88	0.40	Replaces Navistar #390226C91	
Peterbilt	35500	5.00	5.25	5.81	0.21	Peterbilt #14-11039
Thomas	35520	3.50	3.63	4.19	0.40	1990-84 Saf-t-liner Models w/3208T
	35520	3.50	3.63	4.19	0.40	Replaces Thomas #61240207
	35131	4.00	4.12	4.69	0.40	1989-84 Thomas School Bus w/3208T
	35131	4.00	4.12	4.69	0.40	Replaces Thomas #61240208

INFORMATION
& BUILD TO
ORDER

TOOLS AND
ACCESSORIES

SCHOOL BUS

MEDIUM
DUTY TRUCK
GVW 3-6

HEAVY DUTY
TRUCK
GVW 7-8

APPLICATION
BY ENGINE

NOISE AND
BACKPRESSURE
DATA

TRACTOR

MUFFLER
SPECS

O.E. CROSS
INDEX

ACCESSORIES

FLARED ADAPTERS

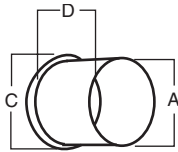

Style A

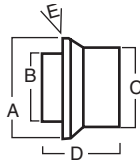

Style B

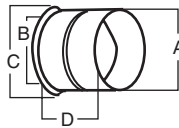

Style C

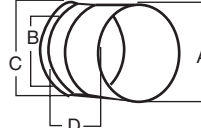

Style D

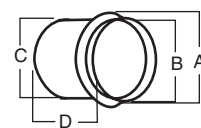

Style E

Part No.	Style	A	B	C	D	Flare	Application	Used w/ V-Band Clamp
41873	D	4.00 OD	2.875 ID	3.937 OD	3.50	20°		35495
41645	A	3.00 ID	—	3.78	3.00	20°	Ford Motor Co, Detroit Diesel 6V71, 6V73, Cummins V555, V902	
41646	C	3.00 OD	3.00 ID	3.62	4.00	22°	Detroit Diesel 6V71	35695
41659	A	3.00 OD	—	3.50	3.50	45°		35695
41656	C	3.00 OD	3.125 ID	3.625 OD	4.75	45°		35449
41662	A	3.00 ID	3.00 ID	3.90 OD	2.50	20°	GMC Truck/Bus w/8.2N	35495
41865	A	3.50 OD	—	4.00	3.50	22°	Cat 3208T	35520
41862	A	3.50 OD	—	4.00 OD	5.00	45°	Detroit Diesel	35494
41657	C	3.50 ID	3.50 ID	4.00 OD	4.75	45°		35494
41647	C	3.50 ID	3.58 ID	4.30	4.00	20°	Detroit Diesel 8V-71	35804
41872	C	3.50 OD	3.63 ID	4.25 OD	4.00	22°	Detroit Diesel 8V-71	35804
41864	C	3.50 OD	3.63 ID	4.25 OD	4.00	22°	Detroit Diesel 8V-71	35804
41648	A	3.50 OD	—	4.30	3.00	20°	Detroit Diesel 8V92, 4-53	35520
41649	A	3.50 OD	—	4.00	3.00	45°	Detroit Diesel	35494
35110	A	3.69 OD	—	4.25 OD	1.50	20°	Navistar	—
41860	D	4.00 OD	3.75 OD	4.25 OD	4.00	22°	Detroit Diesel 8V-71	35804
41650	C	4.00 OD	4.00 ID	4.75	4.00	22°	Detroit Diesel 12V71	35641
41651	D	4.00 OD	3.50 ID	4.25	4.00	20°	Detroit Diesel 8.2N, Cummins VT225	35496
41863	C	4.00 OD	4.00 ID	4.50 OD	4.75	45°		35805
41652	A	4.00 OD	—	4.80	3.00	20°	Detroit Diesel 6-71, 8.2N, 8.2T, Mack	35499
41653	A	4.00 OD	—	4.50	5.00	45°	Cummins	35805
41688*	B	5.00 OD	4.50 OD	5.15 OD	4.45	20°	Detroit Diesel 8V-71T, 16V-71T, 6V-92T, 8V-92T	35746
41654	A	5.00 OD	—	5.50	5.00	45°	Cummins	35500
41655	A	5.00 OD	—	5.72	3.00	20°	Caterpillar Turbo, Cummins Turbo, Navistar	35806
41696	A	5.00 OD	—	5.75 OD	5.50	20°	Navistar	35806
41689	A	5.00 OD	—	5.875	6.25	20°	T-50 Turbo Charger	35806
41658	C	5.00 OD	5.00 ID	5.50 OD	4.75	45°		35500
41875	D	5.00 ID	5.00 OD	5.75 OD	5.00	20°		—
35747	B	5.15 OD	4.55 OD	4.81 OD	1.94	20°	Detroit Diesel 8V-71T, 16V-71, 6V-92T, 8V-92T, 16V-92T	35746
41690	E	5.69 OD	5.00 OD	5.00 OD	6.00	—	Cummins Engines	35806

* With machined ring.

ACCESSORIES

GASKET IDENTIFICATION CHARTS

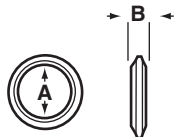

Figure 1

Gasket No.	A	B
31400†	2 ¹ / ₃₂	1 ⁹ / ₃₂
31405†	2 ³ / ₈	9 ¹ / ₁₆
31508 ¹	2 ⁹ / ₁₆	1 ¹ / ₂
31572	2 ⁹ / ₃₂	9 ¹ / ₁₆
31818	2 ¹ / ₂	1 ⁹ / ₃₂
31821	2 ³ / ₄	5 ⁵ / ₈

† Shipped in lots of 10 - Std. Carton

¹ Sintered Iron Material

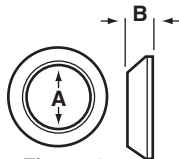

Figure 2

Gasket No.	A	B
31417 ¹	2 ¹ / ₈	1 ⁷ / ₃₂
31510 ¹	2 ⁵ / ₃₂	2 ³ / ₃₂

¹ Sintered Iron Material

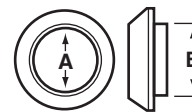

Figure 3

Gasket No.	A	B
31394	2 ¹ / ₄	2 ¹ / ₂

FLANGE IDENTIFICATION CHARTS

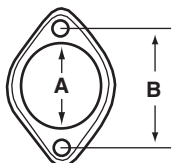

Figure 1

Flange No.	A	B
31873	2 ¹¹ / ₃₂	3 ³ / ₄
31887	2 ¹⁹ / ₃₂	3 ³ / ₄

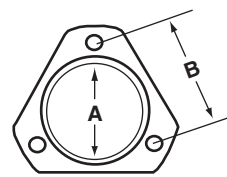
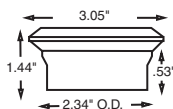

Figure 2

Flange No.	A	B
31803	2 ¹ / ₈	2 ³ / ₄
31850	2 ³ / ₈	3
31875	2 ⁷ / ₁₆	3 ¹¹ / ₁₆
31883	2 ⁵ / ₈	3 ¹ / ₁₆

Flange No.	A	B
31891	2 ¹ / ₈	2 ⁵ / ₈
31923	2 ¹¹ / ₁₆	3
31952	2 ⁵ / ₈	3 ¹ / ₄

SINGLE PIECE INSERTS



35490

Chevrolet/GMC
Medium Truck/
Bus w/366, 427
engine.

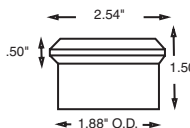

35597

Chevrolet/GMC
Medium Truck/
Bus w/350
engine.

ALUMINIZED TILT CAB CONNECTORS

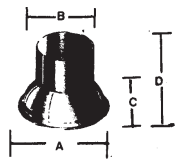

TOP

Part No.	A	B	C	D
41479	5 ³ / ₄ OD	4 OD	2 ¹ / ₂	7
41539	6 ³ / ₄ OD	5 OD	3 ¹ / ₂	7 ³ / ₄



BOTTOM

Part No.	A	B
41480	4 ID	4 ¹ / ₂
41540	5 ID	5 ¹ / ₄

INFORMATION
& BUILD TO
ORDER

TOOLS AND
ACCESSORIES

SCHOOL BUS

MEDIUM
DUTY TRUCK
GVW 3-6

HEAVY DUTY
TRUCK
GVW 7-8

APPLICATION
BY ENGINE

NOISE AND
BACKPRESSURE
DATA

TRACTOR

MUFFLER
SPECS

O.E. CROSS
INDEX

ACCESSORIES

CONNECTORS — REDUCERS

I.D.-I.D. CONNECTOR

Connects O.D. pipes and/or tubing of the same size.

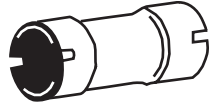

Part No.	I.D. - I.D.	Lgth.
41919	1½-1½	4
41921	1⅝-1⅝	4
41926	1¾-1¾	4
41933	1⅞-1⅞	4
41940	2-2	4
41948	2⅛-2⅛	4
41951	2¼-2¼	4
41957	2½-2½	4
41967	2¾-2¾	4
41812	3-3	4
41892	3-3	6
41893	3½-3½	6
41895	4-4	8
41899	5-5	8
41557	6-6	8

I.D.-O.D. CONNECTOR

Connects O.D. & I.D. pipes and/or tubing of the same size.

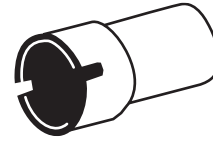

Part No.	I.D. - O.D.	Lgth.
41810	1½-1½	4
41920	1½-1½	12
41882	1¾-1¾	5
41931	1¾-1¾	12
41759	1⅞-1⅞	4
41944	2-2	4½
41902	2-2	10
41947	2-2	12
41954	2¼-2¼	4½
41956	2¼-2¼	12
41965	2½-2½	4½
41966	2½-2½	12
42596	2½-2½	18
41811	3-3	4
41970	3-3	6
41976	3-3	12
42606	3-3	18
41978	3½-3½	6
41983	3½-3½	12
42127	3½-3½	18
41896	4-4	8
42891	4-4	18
42531	4-4	24
41780	4½-4½	4¾
41897	5-5	8
42126	5-5	18
42530	5-5	24
41889	6-6	8

O.D.-O.D. CONNECTOR

Connects I.D. pipes and/or tubing of the same size.
Also used on manifold outlet.

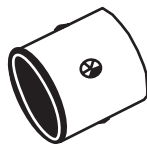

Part No.	O.D. - O.D.	Lgth.
41945	2-2	4½
41964	2½-2½	4½
41971	3-3	6
41979	3½-3½	6
41987	4-4	8
41992	5-5	8

REDUCING BUSHINGS

Reduces the I.D. of a muffler inlet or outlet without increasing the muffler overall length.

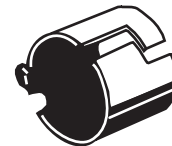

Part No.	O.D. - I.D.
36275	1½-1⅝
35253	2-1⅞
35254	2⅛-2

PACKED 6 BUSHINGS PER CARTON

ACCESSORIES

CONNECTORS — REDUCERS

I.D.-I.D. REDUCER

Reduces O.D. Pipe and/or tubing of different size.

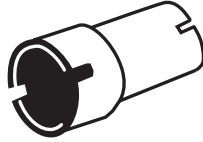

Part No.	I.D. - I.D.	Lgth.
41922	1 ⁵ / ₈ -1 ¹ / ₂	4 ¹ / ₂
41927	1 ³ / ₄ -1 ¹ / ₂	4 ¹ / ₂
41929	1 ³ / ₄ -1 ⁵ / ₈	4 ¹ / ₂
41934	1 ⁷ / ₈ -1 ³ / ₄	4 ¹ / ₂
41886	2-1 ¹ / ₂	4
41941	2-1 ³ / ₄	4 ¹ / ₂
41943	2-1 ⁷ / ₈	4 ¹ / ₂
41952	2 ¹ / ₄ -2	4 ¹ / ₂
41958	2 ¹ / ₂ -2	4 ¹ / ₂
41961	2 ¹ / ₂ -2 ¹ / ₄	4 ¹ / ₂
41973	3-2 ¹ / ₂	6
41687	3-2 ³ / ₄	6
41981	3 ¹ / ₂ -3	6
41989	4-3	6
41894	4-3 ¹ / ₂	6
41898	5-4	8
41879	5-4 ¹ / ₂	6
41998	6-5	6

I.D.-O.D. REDUCER

Reduces larger O.D. pipe and/or tubing to smaller I.D. pipe. Also used as muffler bushing or manifold outlet.

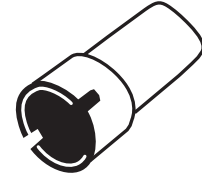

Part No.	I.D. - O.D.	Lgth.
41855	1 ¹ / ₂ -1 ³ / ₈	4
41923	1 ⁵ / ₈ -1 ¹ / ₂	4 ¹ / ₂
41928	1 ³ / ₄ -1 ¹ / ₂	4 ¹ / ₂
41930	1 ³ / ₄ -1 ⁵ / ₈	4 ¹ / ₂
41932	1 ⁷ / ₈ -1 ³ / ₄	2 ⁵ / ₈
41939	2-1 ³ / ₄	2 ⁵ / ₈
41942	2-1 ⁷ / ₈	4 ¹ / ₂
41949	2 ¹ / ₈ -2	4 ¹ / ₂
41888	2 ¹ / ₄ -1 ⁷ / ₈	4
41955	2 ¹ / ₄ -2	4 ¹ / ₂
41854	2 ¹ / ₄ -2 ¹ / ₈	4
41959	2 ¹ / ₂ -2	4 ¹ / ₂
41962	2 ¹ / ₂ -2 ¹ / ₄	4 ¹ / ₂
41999	2 ³ / ₄ -2 ¹ / ₂	8
41974	3-2 ¹ / ₂	6
41982	3 ¹ / ₂ -3	6
41563	4-3	6
41984	4-3 ¹ / ₂	6
41909	5-4	6
41997	6-5	6

O.D.-O.D. REDUCER

Reduces I.D. pipe and/or tubing of different sizes.

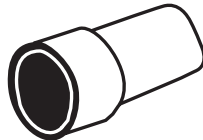

Part No.	O.D. - O.D.	Lgth.
41908	2-1 ⁷ / ₈	5 ¹ / ₄
41937	2-1 ¹³ / ₁₆	4 ¹ / ₂
41700	2 ¹ / ₄ -2	4 ¹ / ₂
41917	2 ¹ / ₂ -2	4 ¹ / ₂
41918	2 ¹ / ₂ -2 ¹ / ₄	4 ¹ / ₂
41890	4-3	8
41891	5-4	8
41845	5-4 ¹ / ₂	6
41844	6-4	6
41515	6-5	8

O.D.-I.D. REDUCER

Reduces larger I.D. pipe and/or tubing to smaller O.D. pipe. Also used as muffler bushing or manifold outlet.



Part No.	O.D. - I.D.	Lgth.
41883	1 ¹ / ₂ -1 ³ / ₈	4
41924	1 ⁵ / ₈ -1 ¹ / ₂	4 ¹ / ₂
41925	1 ³ / ₄ -1 ⁵ / ₈	2 ⁵ / ₈
41885	1 ⁷ / ₈ -1 ¹ / ₂	4 ¹ / ₂
41935	1 ⁷ / ₈ -1 ³ / ₄	4 ¹ / ₂
41946	2-1 ³ / ₄	5 ³ / ₈
41950	2 ¹ / ₈ -2	4 ¹ / ₂
41400	2 ¹ / ₄ -1 ³ / ₄	4 ¹ / ₂
41953	2 ¹ / ₄ -2	4 ¹ / ₂
41960	2 ¹ / ₂ -2	4 ¹ / ₂
41963	2 ¹ / ₂ -2 ¹ / ₄	4 ¹ / ₂
41968	2 ³ / ₄ -2 ¹ / ₂	4 ¹ / ₂
41972	3-2 ¹ / ₂	6
41975	3-2 ³ / ₄	6
41980	3 ¹ / ₂ -3	6
41988	4-3	6
41991	4-3 ¹ / ₂	6
41994	5-4	6
41786	5-4 ¹ / ₂	6
41514	6-5	8

INFORMATION & BUILD TO ORDER

TOOLS AND ACCESSORIES

SCHOOL BUS

MEDIUM DUTY TRUCK GYW 3-6

HEAVY DUTY TRUCK GVV 7-8

APPLICATION BY ENGINE

NOISE AND BACKPRESSURE DATA

TRACTOR

MUFFLER SPECS

O.E. CROSS INDEX



How to Measure:

When you are ready to put Flex Pipe to use, follow these instructions for determining the length to cut the pipe. NOTE: All flexible metal tubing is measured fully extended.

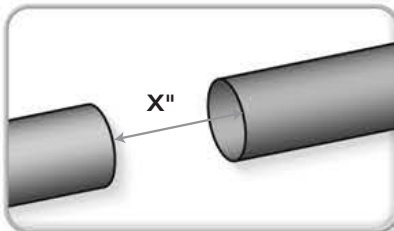

Determine the length (X") of pipe needed for your application by measuring the gap between the two pipes you intend to connect.

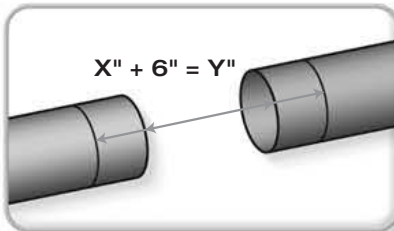

Allow a 3" overlap for each end (add 6" to the measurement from above). This is the length (Y") of Flex Pipe needed.

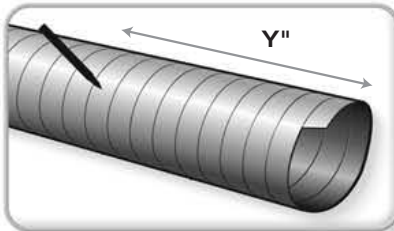

Measure distance needed from the far right side inward. Wrap area to be cut with duct tape. Use a marker to draw a cut guide on the tape. Flex Pipe is now ready to be cut. Cut through the tape. Remove tape from Flex Pipe before using.

How to Cut:

There are three ways to cut Flex Pipe. Select a method that suits your equipment.

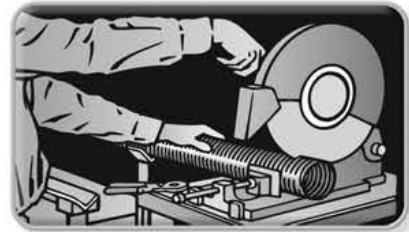

CHOP SAW: For best results, use a 1/16" wide blade. Make sure the Flex Pipe has the open side facing to the right. Align and secure pipe so the cut guide lines up with the Chop Saw blade, and cut.

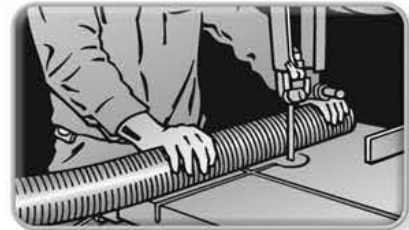

BAND SAW: For best results, use a no-set blade with 24/32 teeth/inch. Make sure Flex Pipe has the open side facing to the right. Align and secure pipe so the cut guide lines up with the Band Saw blade, and cut.

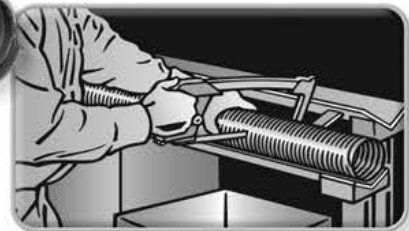

HACK SAW: For best results, use a no-set blade with 24/32 teeth/inch. Make sure Flex Pipe has the open side facing to the right. Align and secure pipe, and cut on the guide line.

How to Order:

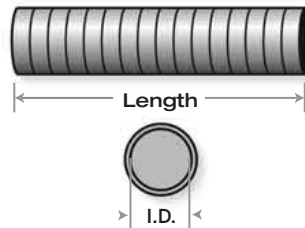

Determine your usage needs. Flex Pipe is sold in a variety of lengths, including precut lengths. All lengths range from 1" to 6" in diameter. Refer to the chart on the reverse side to determine your desired part number. Order by part number, not by the foot.

IMPORTANT:

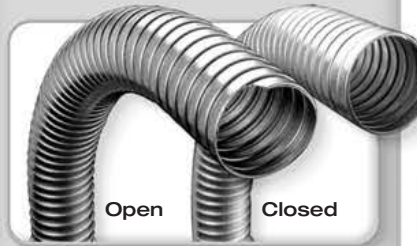

When measuring and cutting, keep the open side of the Flex Pipe to your right. To determine the open end, turn the end of the pipe toward you and look for the rings to wrap on top.

ACCESSORIES

FLEX TUBING

I.D.	6 FOOT LENGTHS§				10 FOOT LENGTHS§				25 FOOT LENGTHS§			
	Stain.	Alz.	Galv.		Stain.	Alz.	Galv.		Stain.	Alz.	Galv.	
	Standard Thickness	H.D. Thickness	Standard Thickness	H.D. Thickness	Standard Thickness	H.D. Thickness	Standard Thickness	H.D. Thickness	Standard Thickness	H.D. Thickness	Standard Thickness	H.D. Thickness
1	—	—	—	—	—	—	—	—	—	—	40000	50001
1¼	—	—	—	—	—	—	—	—	—	—	40001	50002
1½	—	—	46971✕	—	—	—	—	—	—	—	40002	50003
1⅝	—	—	—	—	—	—	—	—	—	—	40013	—
1¾	—	—	46972✕	—	—	—	—	—	—	—	40003	50004
2	—	—	46973✕	—	49060	—	49042	49077	—	—	40005	50005
2⅛	—	—	56026✕	—	—	—	—	—	—	—	40014	—
2¼	—	—	46974✕	—	49061	—	49074	—	—	—	40006	50006
2½	—	—	46975✕	—	49044	49081	49075	49078	40031	—	40007	40030
2¾	—	—	—	—	—	—	49076	49037	—	—	—	—
3	—	—	—	—	49032	49105	49089	49028	40020	50010	40008	40009
3½	—	—	—	—	49033	49106	49090	49029	40021	50011	40024	40010
4	46917	46915	46911	46913	49034	49070	49091	49030	40022	50012	40025	40011
5	46918	46916	46912	46914	49035	49071	49092	49031	40023	50013	40026	40012
6	—	—	—	—	49063	—	—	49036	50015	—	50009	50008

§ Fully Extended.

✕ Packed - 6 per carton, individually labeled.

PRE-CUT FLEX HOSE

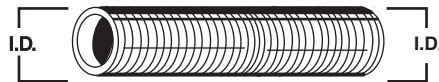

Style ID - ID

Length	3" Dia.			3½" Dia.		
	Galv.	Alz.	Stain.	Galv.	Alz.	Stain.
12	—	—	—	—	—	—
18	42065	—	42492	42066	—	42455
24	53089	—	—	53090	—	—
36	54047	—	—	54048	—	—

Length	4" Dia.			5" Dia.		
	Galv.	Alz.	Stain.	Galv.	Alz.	Stain.
12	41692	—	41691	41694	—	41693
18	42067	52123	42423	42068	52124	42424
24	42069	52128	42338	42070	52129	42339
36	43381	—	43202	43382	—	43203
48	55006	—	54049	55007	—	54050

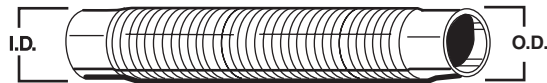

Style ID - OD

Length	3" Dia.			3½" Dia.		
	Galv.	Alz.	Stain.	Galv.	Alz.	Stain.
18	42175	—	—	42176	52067	—

Length	4" Dia.			5" Dia.		
	Galv.	Alz.	Stain.	Galv.	Alz.	Stain.
18	42177	52068	—	42317	—	—

FLEX CONNECTOR



41756

Part No.	OAL	Inlet Dia.	Outlet Dia.	Use Clamp No.
41756	12	4 ID	4 ID	35976 (2)

INFORMATION & BUILD TO ORDER

TOOLS AND ACCESSORIES

SCHOOL BUS

MEDIUM DUTY TRUCK GYW 3-6

HEAVY DUTY TRUCK GVV 7-8

APPLICATION BY ENGINE

NOISE AND BACKPRESSURE DATA

TRACTOR

MUFFLER SPECS

O.E. CROSS INDEX

ACCESSORIES

STANDARD STRAIGHT TUBING

Length	Low Carbon Steel 10'		
	18	17	15
Gauge	.042	0.054	0.065
Thickness			
OD			
1½	49002		
1⅝	49003		
1¾	49004		
1⅞	49005		
2	49006		
2⅛	49013		
2¼			
2½			
2¾			
3			
3¼		49058	
3½			
4			
4½		49056	
5			49015
5½			
6		49027	

Comparison of Gauge to Decimal	
Gauge	Decimal
13	0.082
14	0.069/0.075
15	0.065
16	0.055/0.060
17	0.050/0.054
18	0.042

ALUMINIZED STEEL TUBING

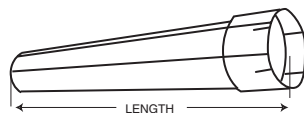

ONE END SWAGED
& SLOTTED
OTHER END - O.D.

Size	Part No.	Length
4	49214	10
5	49215	10

AIR INTAKE ALUMINUM TUBING

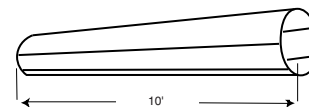

O.D. BOTH ENDS

Size	Part No.
4	49200
5½	49202
6	49203
7	49204

ORDER STRAIGHT TUBING BY THE PIECE:

EXAMPLE: For (1) 10' Stick, order (1) 49200

O.D. - O.D. CONNECTING PIPE



Part No.	O.D. - O.D.	Length
41987	4-4	8
44456	4-4	48
45339	4-4	60

RUBBER GOODS

90° ELBOW

Size	Part No.	DIMENSIONS					
		A	B	C	D	E	F
4	36171	4	5 $\frac{3}{4}$	5 $\frac{3}{4}$	1 $\frac{1}{2}$	1 $\frac{1}{2}$	$\frac{1}{4}$
5	36172	5	6	6	1 $\frac{1}{2}$	1 $\frac{1}{2}$	$\frac{1}{4}$
☆5 $\frac{1}{2}$	36173	5 $\frac{1}{2}$	6 $\frac{1}{2}$	6 $\frac{1}{2}$	1 $\frac{3}{4}$	1 $\frac{3}{4}$	$\frac{1}{4}$
6	36175	6	7	7	2	2	$\frac{1}{4}$
7	36178	7	7 $\frac{9}{16}$	7 $\frac{9}{16}$	2	2	$\frac{1}{4}$

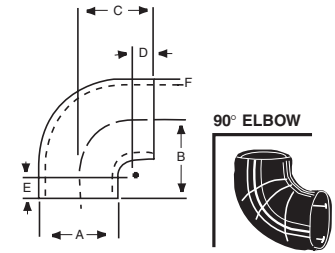

☆ Not recommended for use on Cummins 1710 engine.

90° SHORT RADIUS ELBOW

Size	Part No.	DIMENSIONS					
		A	B	C	D	E	F
6	36176	6	5	5	$\frac{3}{4}$	$\frac{3}{4}$	$\frac{3}{4}$

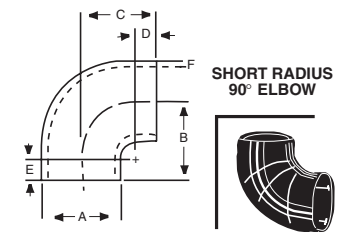

90° REDUCER ELBOW

Size	Part No.	DIMENSIONS						
		A	B	C	D	E	F	G
6 X 5 $\frac{1}{2}$	36177	6	5 $\frac{1}{2}$	6 $\frac{3}{4}$	6 $\frac{3}{4}$	2	1 $\frac{3}{4}$	$\frac{1}{4}$

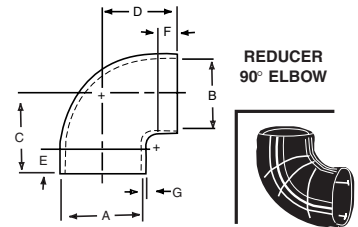

45° ELBOW

Size	Part No.	DIMENSIONS				
		A	B	C	D	E
4	36164	4	45°	$\frac{1}{4}$	1 $\frac{15}{32}$	1 $\frac{15}{32}$
☆5 $\frac{1}{2}$	36168	5 $\frac{1}{2}$	45°	$\frac{1}{4}$	1 $\frac{11}{16}$	1 $\frac{11}{16}$
6	36166	6	45°	$\frac{1}{4}$	1 $\frac{3}{4}$	1 $\frac{3}{4}$

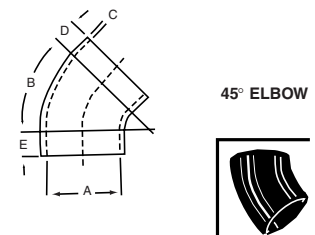

☆ Not recommended for use on Cummins 1710 engine.

INFORMATION
& BUILD TO
ORDER

TOOLS AND
ACCESSORIES

SCHOOL BUS

MEDIUM
DUTY TRUCK
GYW 3-6

HEAVY DUTY
TRUCK
GVW 7-8

APPLICATION
BY ENGINE

NOISE AND
BACKPRESSURE
DATA

TRACTOR

MUFFLER
SPECS

O.E. CROSS
INDEX

ACCESSORIES

RUBBER GOODS (Cont.)

HUMP HOSE

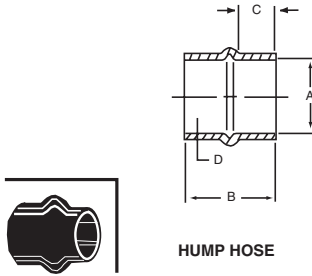

Size	Part No.	DIMENSIONS			
		A	B	C	D
4	36183	4	5¼	2	¼
5½	36185	5½	6	2¼	¼
6	36186	6	7	2¾	¼
7	36187	7	7	2½	5/16

REDUCER INSERT

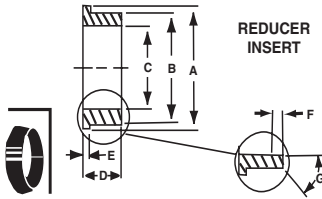

Size	Part No.	DIMENSIONS						
		A	B	C	D	E	F	G
5 X 4	36190	5½	5	4	1¾	¼	½	45°
5½ X 5	36193	6	5½	5	1¾	¼	¼	45°

AIR LINE CLAMPS



Size	Part No.	Size	Part No.
3	36203	5½	36201
3½	36202	6	36206
4	36204	7	36207
5	36205	8	36208

ACCESSORIES

STACK PIPES

Angled (ID)

Inlet Dia.	Length	ALZ.	Chrome
3 ID	18	42262	29120
3 ID	60	—	29505
3 ID	84	—	29700
3½ ID	18	42263	29100
3½ ID	24	—	29205
3½ ID	36	53053	29304
3½ ID	48	—	29416
4 ID	18	42715	29111
4 ID	24	42071	29206
4 ID	36	43320	29305
4 ID	48	44299	29408
4 ID	60	45233	29508
4 ID	72	46896	29600
4 ID	84	—	29702
4 ID	96	—	29800
5 ID	18	42716	29112
5 ID	24	42072	29207
5 ID	36	43321	29306
5 ID	48	44300	29409
5 ID	60	45246	29509
5 ID	72	—	29603
5 ID	84	—	29701
5 ID	96	—	29801
5 ID	108	—	29901
6 ID	18	42128	29118
6 ID	36	53054	—



Angle ID

Angled (OD)

Inlet Dia.	Length	ALZ.	Chrome
3 OD	48	44302	—
3½ OD	24	42132	29204
3½ OD	36	—	29302
3½ OD	48	44634	29406
4 OD	18	42129	29101
4 OD	24	42544	29201
4 OD	36	43718	29307
4 OD	48	44637	29402
4 OD	60	45726	29502
4 OD	69½	46958	—
4 OD	72	—	29605
4 OD	84	—	29704
4 OD	96	—	29806
5 OD	18	42130	29102
5 OD	24	42543	29202
5 OD	36	43719	29308
5 OD	48	44638	29403
5 OD	60	45727	29503
5 OD	69½	46954	—
5 OD	72	—	29604
5 OD	84	—	29705
5 OD	96	—	29807
6 OD	18	42594	—



Angle OD

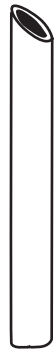

Slant Cut
OD



Slant Cut
ID

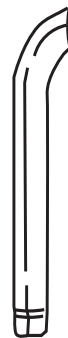

OD



ID

Slant Cut

Inlet Dia.	Length	Chrome	Style
4 OD	36	29300	OD
5 OD	36	29301	OD
5 OD	48	29405	OD
5 OD	60	29511	OD
5 ID	96	29802	iD

Monster Stacks

Inlet Dia.	Length	Chrome	Style
6-5 ID	96	29804	OD
6-5 ID	108	29902	OD
6-5 OD	96	29809	OD
6-5 ID	96	29805	ID

INFORMATION
& BUILD TO
ORDER

TOOLS AND
ACCESSORIES

SCHOOL BUS

MEDIUM
DUTY TRUCK
GVW 3-6

HEAVY DUTY
TRUCK
GVW 7-8

APPLICATION
BY ENGINE

NOISE AND
BACKPRESSURE
DATA

TRACTOR

MUFFLER
SPECS

O.E. CROSS
INDEX

ACCESSORIES

STACK PIPES (Cont.)

Square Cut (ID)



Square Cut ID

Inlet Dia.	Length	ALZ.	Chrome
2½ ID	18	42596	—
3 ID	18	42606	—
3 ID	24	42178	—
3 ID	36	43606	—
3 ID	48	44301	29410
3½ ID	18	42127	—
3½ ID	36	43366	—
3½ ID	48	44308	—
4 ID	18	42891	—
4 ID	24	42531	—
4 ID	36	43319	29314
4 ID	48	44126	29414
4 ID	60	45066	29506
4 ID	72	46892	—
5 ID	18	42126	—
5 ID	24	42530	29213
5 ID	36	43582	29315
5 ID	48	44127	29415
5 ID	60	46778	29507
6 ID	48	44303	—



Square Cut OD

Square Cut (OD)*

Inlet Dia.	Length	ALZ.	Chrome
4 OD	36	—	29309
4 OD	48	44456	—
4 OD	60	45339	29500
5 OD	36	53049	29310
5 OD	48	44457	29401
5 OD	60	45340	29501

* For additional OD sizes and lengths use Straight Tubing.

OTHER STACK PIPES

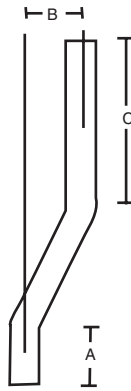

1

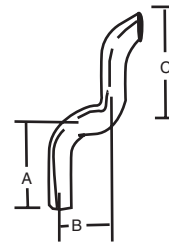

2

Inlet Dia.	Style	A	B	C	Length	ALZ.	Chrome	Replaces OE No.
4 ID	1	6 ⁷ / ₈	1½	30½	48½	45320	—	532395C1
4 OD	1	11	10	29	51	45758	—	—
5 OD	1	11	10	30	60	45800	—	—
4 OD	2	8½	12	22	30½	43587	29208	—
5 OD	2	8	11	21½	29½	43588	29214	—

ACCESSORIES



Style A (OD)



Style B (ID)

DIA.	LENGTH	ALUMINIZED STEEL		CHROME	
		STYLE A	STYLE B	STYLE A	STYLE B
3	12	41095	42448	29135	—
3	18	—	—	—	29120
3 ^{1/2}	12	41096	42449	—	29138
3 ^{1/2}	18	—	—	—	29100
4	12	41097	42447	29139	29140
4	18	42129	42715	—	29111
5	18	42130	42716	—	29112
5	20	—	42377	—	—
6	18	42594	42128	—	—

INFORMATION
& BUILD TO
ORDER

TOOLS AND
ACCESSORIES

SCHOOL BUS

MEDIUM
DUTY TRUCK
GVW 3-6

HEAVY DUTY
TRUCK
GVW 7-8

RAIN CAPS

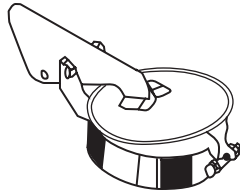

Size	Standard	Chrome
1 ^{1/4}	35608	—
1 ^{1/2}	35225	—
1 ^{3/4}	35226	—
2	35512	—
2 ^{1/4}	35513	—
2 ^{1/2}	35514	—
2 ^{3/4}	35617	—
3	35618	—
3 ^{1/2}	35619	—
4	35907	35931
4 ^{1/2}	35909	—
5	35910	35932
5 ^{1/2}	35164	—
5 ^{3/4}	35393	—

SILENT RAIN CAPS

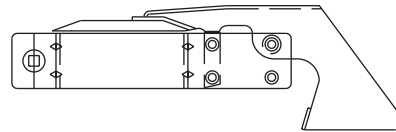

Size	Chrome
4	36158
5	36160

APPLICATION
BY ENGINE

NOISE AND
BACKPRESSURE
DATA

TRACTOR

MUFFLER
SPECS

O.E. CROSS
INDEX

ACCESSORIES

15° ELBOW Style OD-OD

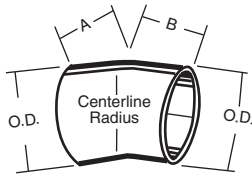

Aluminized Part No.	Dia. OD	Length A-B	Centerline Radius
41204	4	2-2	8
41217	5	4-4	8

20° ELBOW Style ID-OD

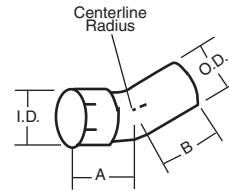

Dia.	Style	A-B	Length Radius	ALZ.
1 1/2	ID-OD	6-6	4	41813
1 3/4	ID-OD	6-6	4	41814
1 7/8	ID-OD	6-6	4	41815
2	ID-OD	6-6	4	41816
2 1/4	ID-OD	6-6	4	41817
2 1/2	ID-OD	6-6	4	41818

30° ELBOW Style ID-OD

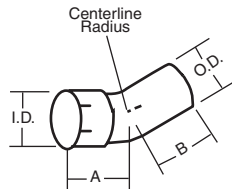

Dia.	Length A-B	Radius	ALZ.
3 1/2	4-4	5	41618
4	4-4	5	41619
5	4-4	6	41620

30° ELBOW Style OD-OD

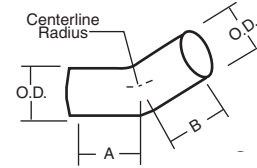

Dia.	Length A-B	Radius	ALZ.
3 1/2	4-4	5	41614
4	4-4	5	41615
5	4-4	6	41616

45° ELBOW Style ID-OD

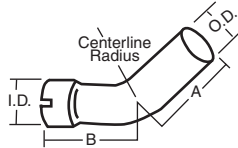

Dia.	Style	Length A-B	Radius	ALZ.	Chrome
1 1/2	ID-OD	6-6	4	41733	—
1 3/4	ID-OD	6-6	4	41734	—
1 7/8	ID-OD	6-6	4	41735	—
2	ID-OD	6-6	4	41187	—
2 1/4	ID-OD	6-6	4 1/2	41188	—
2 1/2	ID-OD	6-6	4	41437+	—
2 1/2	ID-OD	6-6	5	41189	—
2 3/4	ID-OD	6-6	5	41439	—
3	ID-OD	7-7	6	42760+	—
3 1/2	ID-OD	8-8	7	42761+	—
3 1/2	ID-OD	9 1/4-9 1/4	7	—	—
4	ID-OD	5-5	4	41639	—
4	ID-OD	6-6	6	41686	—
4	ID-OD	9 1/4-9 1/4	5	—	29113
4	ID-OD	9 5/16-9 5/16	8	42758+	29126
4	ID-OD	12-12	6	42246+	29143+
5	ID-OD	6-6	5 1/2	41640+	—
5	ID-OD	7-7	8	42355+	—
5	ID-OD	8-8	10	41477	29220+
5	ID-OD	12-12	8	42855+	—
5	ID-OD	12-12	10	42453+	29200
5	ID-OD	15-15	8	53042	—
6	ID-OD	7-7	10	52053	—

45° ELBOWS

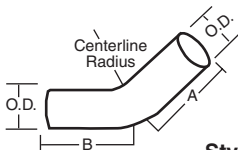

Style OD-OD

Dia.	Style	Length A-B	Radius	ALZ.	Chrome
2 1/2	OD-OD	6-6	4	41438+	—
2 3/4	OD-OD	6-6	5	41440	—
3	OD-OD	4-4	3	41641+	—
3	OD-OD	7-7	6	41428+	—
3 1/2	OD-OD	8-8	7	41429+	—
4	OD-OD	6-6	6	41632+	—
4	OD-OD	8-8	5	41430+	—
4	OD-OD	8-8	8	41475+	—
4	OD-OD	12-12	6	42247+	29144+
5	OD-OD	8-8	5 1/2	41612+	—
5	OD-OD	8-8	8	41431	29105+
5	OD-OD	8-8	10	41476+	—
5	OD-OD	15-15	8	42249	29218
6	OD-OD	7-7	10	52134+	—

60° ELBOW Style ID-OD

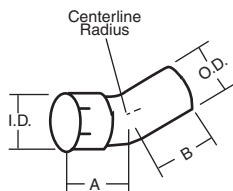

Dia.	Length A-B	Radius	ALZ.
3 1/2	8-8	5	41626
4	8-8	5	41627
5	8-8	6	41628

60° ELBOW Style OD-OD

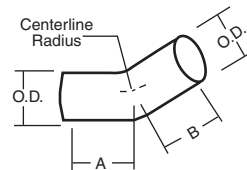

Dia.	Length A-B	Radius	ALZ.
3 1/2	8-8	5	41622
4	8-8	5	41623
5	8-8	6	41624

67° ELBOWS Style OD-OD

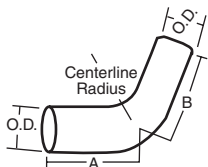

Dia.	Length A-B	Radius	LCS	ALZ.	Chrome
5	7 1/2-11	8	—	42856	29209

70° ELBOWS Style ID-OD

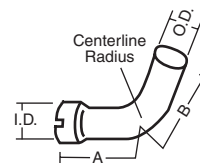

Dia.	Length A-B	Radius	ALZ.
5	7 1/2-11	8	42252

INFORMATION
& BUILD TO
ORDER

TOOLS AND
ACCESSORIES

SCHOOL BUS

MEDIUM
DUTY TRUCK
GVW 3-6

HEAVY DUTY
TRUCK
GVW 7-8

APPLICATION
BY ENGINE

NOISE AND
BACKPRESSURE
DATA

TRACTOR

MUFFLER
SPECS

O.E. CROSS
INDEX

ACCESSORIES

90° ELBOWS

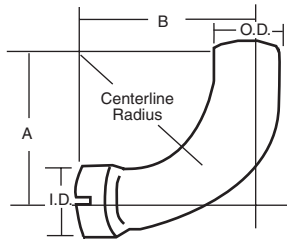

Style ID-OD

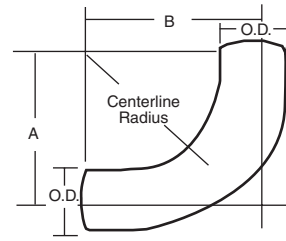

Style OD-OD

Dia.	Centerline Length A-B	Rad.	ALZ.	Chrome	Stain-less
1½	6¾-6¾	4	41231	—	—
1¾	6¾-6¾	4	41000	—	—
1⅞	6¾-6¾	4	41230	—	—
2	6¾-6¾	4	41001	—	—
	7⅞-6¾	4	41154	—	—
	9-9	4½	41558+	—	—
2¼	6-6	4	41098	—	—
2½	6¼-6¼	4	41002	—	—
	12-12	5	41441	—	—
2¾	6¾-6¾	5	41099	—	—
	12-12	5	41442+	—	—
3	8-8	6	41365+	29145+	—
	10-12	5	41535+	—	—
	12-12	5	41534+	—	—
	12½-12½	6	—	29116	—
	14-14	8	42759+	—	—
3½	14-14	6	42445+	—	—
	6½-6½	3½	41633+	—	—
	10¼-10¼	5	41768	—	—
	9-9	7	41366+	—	—
4	16-16	5	42185+	—	—
	6-6	4	41630+	—	—
	8½-13	5	42085	—	—
	10-10	5	41378+	29146+	—
	10-10	8	41367+	—	—
	12-12	6	41472	29109	—
	16-16	8	53094+	29211+	52059
	18-18	8	42937+	—	—
5	25-32	8	43168+	—	—
	15½-15½	6	42356+	—	—
	8½-8½	6	41769	—	—
	9½-9½	5½	42763+	29108+	—
	10-10	8	—	29212+	—
	11½-26¾	5½	43613	—	—
	12-12	6	41532+	29210+	—
	15-15	5½	42272+	—	—
	15-15	8	42858+	29147+	—
	15½-15½	10	—	29129	—
	16½-16½	10	43348+	—	—
6	18-18	10	42938+	—	—
	32-25	8	43438+	—	—
	12-12	10	52058	—	—
	15-15	10	42944+	—	—
	26-26	10	44569+	—	—

Dia.	Centerline Length A-B	Rad.	ALZ	Chrome
2	9-9	4½	41631+	—
2¼	12-12	5	41762	—
2½	12-12	5	41432+	—
2¾	12-12	5	41433+	—
	3-3	3	41221+	—
	6-6	3	41685+	—
	7-7	3	41536+	—
3	10-10	6	41434+	—
	14-14	8	42344+	—
	3½-3½	3½	41222+	—
	6-6	3½	41537+	—
3½	6½-6½	3½	41637+	—
	12-12	7	41435	—
	16-16	8	42288+	—
	4-4	4	41223+	—
	7-7	5	41256+	29103+
4	8-8	4	41474+	—
	8¼-10½	4	52138+	—
	9-16	5	42936+	—
	10-10	6	52119+	29127
	10-13½	6	42407+	—
	12-12	5	41638+	—
	12-12	6	41473+	—
	16-16	8	43698+	29150
	18-18	8	42857	—
	22½-30	8	44112+	—
5	5-5	5½	41224+	—
	7½-7½	6	52135+	—
	7½-13½	5½	42253+	—
	8½-8½	6	41538+	—
	9-11½	5½	53095	—
	8⅜-12⅝	6	42081	—
	8¾-14¼	5½	42186	—
	9½-9½	6	41832+	29151+
	10-16	6	42147+	—
	11-16	5½	42125+	—
	12-12	6	41436+	—
	15-15	5½	42274+	—
	12-12	8	—	29121+
	15-15	8	42939+	—
17½-17½	10	43699+	—	
6	18-18	10	42940+	—
	6½-6½	6½	41583+	—
	10-10	10	41559+	—
	12-12	10	41560+	—
15-15	10	42562+	—	

ACCESSORIES

UNIVERSAL HEAVY DUTY HANGERS & BRACKET

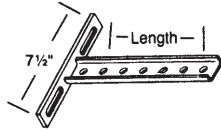

For use on 4"—5" OD Applications

Part No.	Length
35530	9 1/4
35556	14

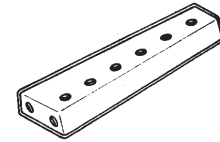

35357
Frame Mount Bracket

SWIVEL HANGERS

Specially designed hanger, engineered to solve essentially any hanger problem. Hanger swings from 0° to ± 45° and also has complete 360° rotation

Part No.	Length
35103	9 1/2
35898	17

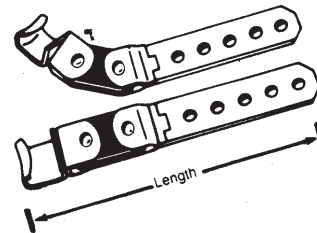

SPLITTER "T" ADAPTER PIPE

Converts a single system into a dual system on popular diesel engines.

Part No. w/o Bracket	Part No. w/Bracket	A	B	C	D
40221	—	4 OD	4 ID	12	20
—	40247	4 OD	4 ID	11 1/4	18 3/4
—	40364	5 OD	5 ID	15	24 3/4
40220	—	5 OD	5 OD	11	19
40223	—	5 OD	5 ID	13 1/2	22

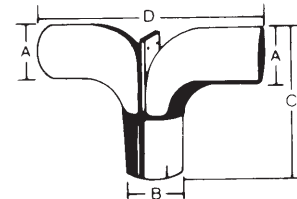

CONVENTIONAL "Y" PIPE

O.E. replacement on various models of trucks. Can be used to convert dual to single exhaust.

Part No.	A	B	C	D
40219	4 ID	3 OD	8 1/2	14
40256	4 ID	4 OD	11	16
40257	5 ID	5 OD	11 1/2	16

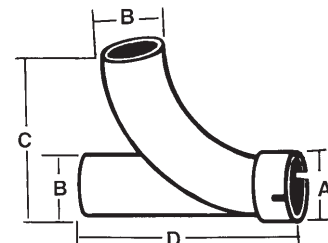

INFORMATION & BUILD TO ORDER

TOOLS AND ACCESSORIES

SCHOOL BUS

MEDIUM DUTY TRUCK GYW 3-6

HEAVY DUTY TRUCK GVV 7-8

APPLICATION BY ENGINE

NOISE AND BACKPRESSURE DATA

TRACTOR

MUFFLER SPECS

O.E. CROSS INDEX

ACCESSORIES

MUFFLER HANGERS

Heavy Duty muffler body clamp and hanger strap. The strap can be bent and twisted to fit the installation. Use for horizontal or vertical mount. Use two for maximum rigidity.

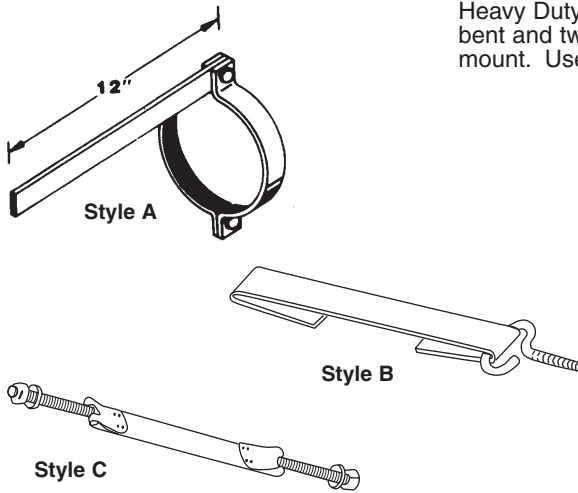

Part No.	Style	Fits Body Diameter
35745	B	7—8 ³ / ₈
35854	A	6
35855	A	7
35338	A	8
35856	A	8 ¹ / ₂
35972	A	9
35983	A	10
35733	A	8 ¹ / ₄ x 11 ¹ / ₂
35984	A	10 x 15
35899	A	11 ¹ / ₈
36209	C	10 x 15
●36448	A	12

PIPE HANGERS

Clamp and hanger strap, made of heavy gauge steel to hold tail pipe and exhaust pipe in a rigid position.

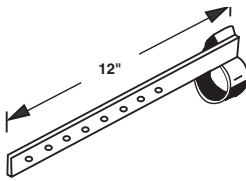

Part No.	Fits Pipe Diameter	Part No.	Fits Pipe Diameter
35604	2 ¹ / ₂	35853	4
35605	2 ³ / ₄	35734	5
35606	3	35855	7
35852	3 ¹ / ₂		

UNIVERSAL HANGER & BRACKET

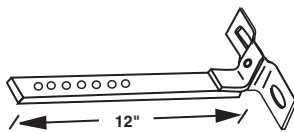

35966
Fits 2³/₄" - 4¹/₂" O.D.

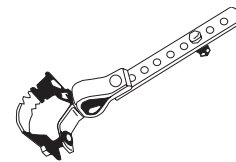

35600
Fits 1¹/₂" to 2¹/₄" OD

UNIVERSAL HANGERS



35209

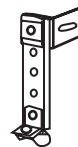

35210

O.E. Type Hanger	Universal Hanger	O.E. Type Hanger	Universal Hanger
35315	35209	35544	35210
35517	35209		

ACCESSORIES

180° PIPE SHIELDS AND CLAMP KITS

PIPE SHIELDS	
Part No.	Specifications
29039	Aluminized 4"-5" x 48" Pipe Shield w/o Mtng. Clamps, Round Holes
29041	Stainless Steel 4"-5" x 48" Pipe Shield w/o Mtng. Clamps, Round Holes
29045	Stainless Steel 3½"-5" x 48" Pipe Shield w/o Mtng. Clamps w/Horizontal Slots
29047	Stainless Steel 6" x 48" Pipe Shield w/o Mtng. Clamps, Round Holes

PIPE SHIELD CLAMP KIT (2 Clamps)	
Part No.	Specifications
35884☆	Chrome Clamp Kit for 4" Diameter Pipe
35885☆	Chrome Clamp Kit for 5" Diameter Pipe
35348☆	Chrome Clamp Kit for 6" Diameter Pipe
35440☆	Zinc Plated Clamp Kit for 3½" Diameter Pipe
35441☆	Zinc Plated Clamp Kit for 4" Diameter Pipe
35442☆	Zinc Plated Clamp Kit for 5" Diameter Pipe
35372☆	Zinc Plated Clamp Kit for 6" Diameter Pipe

☆ Kit contains two clamps.

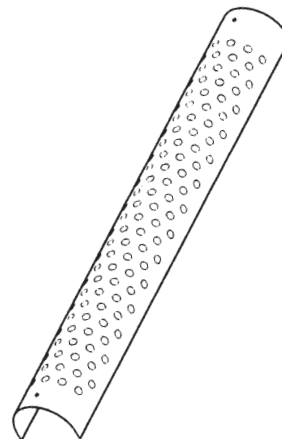

INFORMATION
& BUILD TO
ORDER

TOOLS AND
ACCESSORIES

SCHOOL BUS

MEDIUM
DUTY TRUCK
GVW 3-6

HEAVY DUTY
TRUCK
GVW 7-8

CHROME GRAB HANDLE



Part No.	Specifications
29110	18" Length
29219	24" Length

Mounting Bolts included.

APPLICATION
BY ENGINE

NOISE AND
BACKPRESSURE
DATA

360° ALUMINIZED PIPE SHIELD

Part No.	Fits Diameter	Length of Guard
29030☆	3" Pipe	36"
29031☆	4" Pipe	36"

☆ Clamps (2) included in box

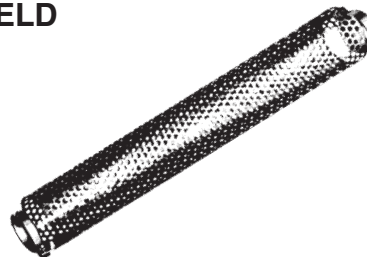

TRACTOR

MUFFLER
SPECS

No. 35796 UNIVERSAL MOUNTING BRACKET

Use for either cab or mast mount. Fits 4"—5" piping.

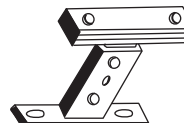

O.E. CROSS
INDEX

ACCESSORIES

ALUMINIZED AND STAINLESS STEEL MUFFLER AND PIPE SHIELDS (Cont.)

180° MUFFLER SHIELDS AND CLAMP KITS

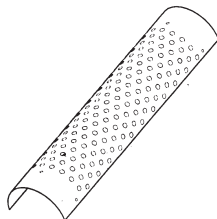

180° MUFFLER SHIELDS

MUFFLER SHIELDS	
Part No.	Specifications
29029	Aluminized 8"-10" x 42" Muffler Shield w/o Mtng. Clamps, Round Holes
29052	Aluminized 8"-10" x 51" Muffler Shield w/o Mtng. Clamps, Round Holes
29043	Aluminized 8"-10" x 51" Muffler Shield w/o Mtng. Clamps, Round Holes
29036	Stainless Steel 8"-10" x 42" Muffler Shield w/o Mtng. Clamps, Round Holes
29042	Stainless Steel 8"-10½" x 51" Muffler Shield w/o Mtng. Clamps, Round Holes
29044	Stainless Steel 8"-10" x 51" Muffler Shield w/o Mtng. Clamps, w/Horizontal Slots



180° MUFFLER SHIELD CLAMP KITS

MUFFLER SHIELD CLAMP KITS (2 Clamps)	
Part No.	Specifications
36224☆	Chrome Clamp Kit for 8" Diameter Muffler
35886☆	Chrome Clamp Kit for 8½" Diameter Muffler
35887☆	Chrome Clamp Kit for 9" Diameter Muffler
35933☆	Chrome Clamp Kit for 10" Diameter Muffler
35935☆	Chrome Clamp Kit for 10⅞" Diameter Muffler
35790☆	Zinc Plated Clamp Kit for 9" Diameter Muffler
35791☆	Zinc Plated Clamp Kit for 10" Diameter Muffler
35792☆	Zinc Plated Clamp Kit for 10½" Diameter Muffler

☆ Kit contains two clamps.

ACCESSORIES

ALUMINIZED AND STAINLESS STEEL MUFFLER AND PIPE SHIELDS 270° MUFFLER SHIELDS AND CLAMP KITS

MUFFLER SHIELDS	
Part No.	Specifications
29050	Aluminized 6"-9" x 50" Muffler Shield w/Mtng. Clamps, Slotted Holes
29048	Aluminized 8½"-10½" x 48" Muffler Shield w/o Mtng. Clamps, Round Holes
29034†	Aluminized 9"-10" x 32" Muffler Shield w/o Mtng. Clamps, Round Holes
29046▼	Stainless Steel 8½"-10½" x 48" Muffler Shield w/o Mtng. Clamps, Round Holes
29051	Stainless Steel 9"-10" x 51" Muffler Shield w/o Mtng. Clamps, Round Holes

▼ Shield only, requires (2) 35370 clamps and 29110 Grab Handle.

† Shield only, requires 35216 Clamp Kit for 9" Dia. Muffler & 35370 Clamp Kit for 10" Dia. Muffler.

MUFFLER SHIELD CLAMP KIT (2 Clamps)	
Part No.	Specifications
36227	Aluminized Clamp Kit for 9" Muffler
36226	Aluminized Clamp Kit for 10" Muffler
35216	Chrome Clamp Kit for 9" Muffler
35370	Chrome Clamp Kit for 10" Muffler

UNIVERSAL MUFFLER SHIELD KIT	
Part No.	Specifications
29032	Universal Stainless Steel Shield Kit for 8"-10" x 45" Mufflers, includes Grab Handles and Clamps

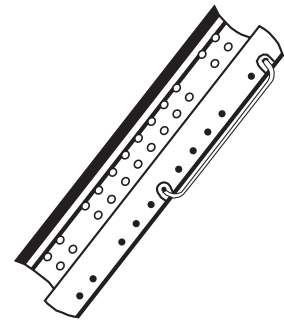
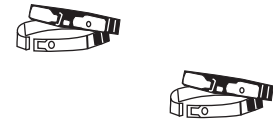
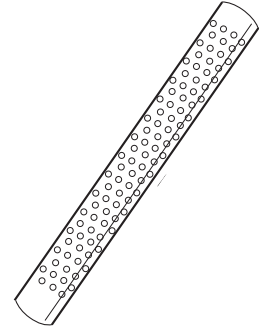

270° PIPE SHIELDS AND CLAMP KITS

PIPE SHIELDS	
Part No.	Specifications
29033	Aluminized 4"-5" x 36" Pipe Shield w/o Mtng. Clamps, Round Holes
29055	Aluminized 4" x 48" Pipe Shield w/o Mtng. Clamps, Use (2) 35441 Clamps, Slotted Holes

PIPE SHIELD CLAMP KIT (2 Clamps)	
Part No.	Specifications
35884	Chrome Plated Clamp Kit for 4" Diameter Pipe
35885	Chrome Plated Clamp Kit for 5" Diameter Pipe
35441	Zinc Plated Clamp Kit for 4" Diameter Pipe
35442	Zinc Plated Clamp Kit for 5" Diameter Pipe

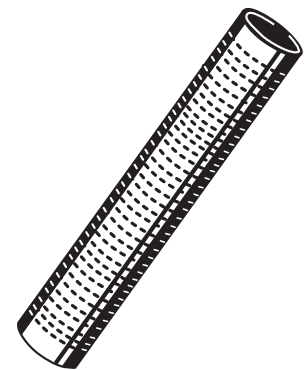

INFORMATION
& BUILD TO
ORDER

TOOLS AND
ACCESSORIES

SCHOOL BUS

MEDIUM
DUTY TRUCK
GVW 3-6

HEAVY DUTY
TRUCK
GVW 7-8

APPLICATION
BY ENGINE

NOISE AND
BACKPRESSURE
DATA

TRACTOR

MUFFLER
SPECS

O.E. CROSS
INDEX

ACCESSORIES

GENERAL SERVICE MUFFLER SPECIFICATIONS

Designed for horizontal or vertical installation. Straight-through flow for minimum backpressure.



Muffler No.	I.D. Inlet	Shell Diameter	Shell Length	Overall Length	I.D. Outlet
22356	2½	6	30	38	2½
22355	2¾	6	29	37	2¾
21468	3	6	21	30	3
21470	3½	7	30	38	3½
21471	4	7	27¼	36	4
22572	4	9	20	27	4
*22966	4	10	44	51	5
*22969	4	10	44	51	4
22962	4	10	44	51	5
22936	4	9	44	51	4
22965	4	9	44	51	4
22941	4	9	44	51	5
*22970	4	9	44	51	5
22914	5	9	33½	40	5
*22964	5	9	44	51	5
*22963	5	10	44	51	5
■22980	5	10	44	51	5
†22981	5	10	44	51	5
22938	5	10⅞	60	66½	5
22920	5	10	44	51	5
22940	5	9	44	51	5

- * MEGA FLOW MUFFLER
- NOISE BRAKER MUFFLER
- † DUAL STACK APPLICATION

Features Include:

- ALL ALUMINIZED SHELLS, TUBES AND HEADS
- TAPERED HEADS - DESIGNED TO SHED MOISTURE WHEN MOUNTED IN THE VERTICAL POSITION

UNIVERSAL TYPE RESONATORS

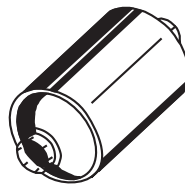

Four popular sizes specially designed for use in combination with gas or diesel heavy duty mufflers.

Part No.	21146	22538	21467	21464	21835
Inlet Diameter (ID)	3	3	3½	4	5
Outlet Diameter (ID)	3	3	3½	4	5
Shell Diameter	7	9	7	7	9
Shell Length	12	11½	12	12	12
Overall Length	20	16	20	20	20

SPARK ARRESTORS

SPARK ARRESTOR APPROVED
UNDER USDA FOREST
SERVICE STANDARD 5100-1a

As indicated by this symbol
▼ embossed on all unit shells.

NOTE:
INLET IS SLOTTED END

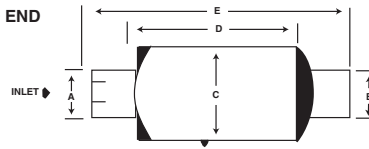

- Tested and U.S. Forest Service approved for vertical or horizontal installations.
- All Spark arrestors 95% or greater efficiency on incendiary sparks - reduces fire hazard.
- Centrifugal force separates solids from exhaust gas.
- Aluminized construction with stainless steel critical parts.

Part No.	Body Diameter	Inlet and Outlet Diameter	Body Length	Overall Length
35807	4 $\frac{1}{4}$	1 $\frac{1}{2}$ ID - 1 $\frac{1}{2}$ OD	3 $\frac{1}{8}$	6
21578	5 $\frac{5}{8}$	2 ID - 2 ID	6 $\frac{3}{8}$	11
21579	5 $\frac{5}{8}$	2 $\frac{1}{2}$ ID - 2 $\frac{1}{2}$ ID	8 $\frac{5}{8}$	12 $\frac{7}{8}$
21580	6 $\frac{5}{8}$	3 ID - 3 $\frac{1}{8}$ OD	10 $\frac{9}{16}$	14 $\frac{7}{8}$
21581	7 $\frac{5}{8}$	3 $\frac{1}{2}$ ID - 3 $\frac{5}{8}$ OD	12	17 $\frac{5}{8}$
21582	8 $\frac{1}{2}$	4 ID - 4 $\frac{1}{8}$ OD	14 $\frac{5}{8}$	21 $\frac{3}{16}$
21584	9 $\frac{5}{8}$	5 ID - 5 $\frac{1}{8}$ OD	16	24

SELECTING A SPARK ARRESTOR

Seven models of different sizes and capacities are currently being produced. Generally, if a spark arrester will fit on the exhaust pipe of an engine, it will also have acceptable back pressure for that engine. In some cases, a larger size spark arrester will be required to stay within back pressure limits and in those cases, adapters will have to be used.

MUFFLER/SPARK ARRESTOR

Designed for use on Onan Generator on Motor Home Applications.

Muffler No.	OD Inlet	Shell Diameter	Shell Length	Overall Length	OD Outlet
21585	1 $\frac{1}{2}$	4 $\frac{1}{4}$	18 $\frac{1}{2}$	21	1 $\frac{3}{8}$

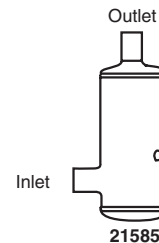

INFORMATION
& BUILD TO
ORDER

TOOLS AND
ACCESSORIES

SCHOOL BUS

MEDIUM
DUTY TRUCK
GVW 3-6

HEAVY DUTY
TRUCK
GVW 7-8

APPLICATION
BY ENGINE

NOISE AND
BACKPRESSURE
DATA

TRACTOR

MUFFLER
SPECS

O.E. CROSS
INDEX