

TRACTOR

Models	Muffler No.	Inlet Clamp No.	Muffler Specs.				
			I.D. Inlet Dia.	O.D. Outlet Dia.	Shell Dia.	Overall Length	Shell Length

ALLIS-CHALMERS

Models	Muffler No.	Inlet Clamp No.	I.D. Inlet Dia.	O.D. Outlet Dia.	Shell Dia.	Overall Length	Shell Length
21060							
22023							
22028							
22032							
22042							
22043							
22861							
22904							
GAS							
B, 1B, C, CA, RC, B125, TDL (V)	22028	N.R.	1½ O.D.	1½	¾	32 ⁹ / ₁₆	19¾
D10, D12, D14, D15, G138, G160 Up to Ser. No. 9001 (V)	22028	N.R.	1½ O.D.	1½	¾	32 ⁹ / ₁₆	19¾
WD, 2CP (V)	22042	35343	1¾ O.D.	1¾	¾	31½	15½
WD45, D-17 Up to Ser. No. 32000, 2CP, W226, G226, D, E (V)	22043	N.R.	1¾ O.D.	1¾	¾	31¼	17
D17 From Ser. No. 32001 thru Ser. No. 42000 (V)	22023	35335	1⅞	1½	4¼	18	13
190 After Ser. No. 19000 (V)	21060 ¹³ w/42596	35337	2 ⁷ / ₁₆	2½	5⅞	32	17 ¹¹ / ₁₆
DIESEL							
B, 1B, C, CA, RC, TDL (V)	22028	N.R.	1½ O.D.	1½	¾	32 ⁹ / ₁₆	19¾
D10, D12, D14, D15 Up to Ser. No. 9001 (V)	22028	N.R.	1½ O.D.	1½	¾	32 ⁹ / ₁₆	19¾
WD, 2CP (V)	22042	35343	1¾ O.D.	1¾	¾	31½	15½
WD45, D-17 Up to Ser. No. 32000 (V)	22043	N.R.	1¾ O.D.	1¾	¾	31¼	17
7000, 7020 w/301 Turbocharged Eng.	22861 ¹⁴	35753	3½	3⅞	5⅞	42	28
7000, 7010, 7020, 7030, 7040, 7045, 7050, 7060 (V)	22904	35794	3	3	6⅞	48	32
LP							
WD45, D-17 Up to Ser. No. 32000, 2CP, W226 G226, D, E (V)	22043	N.R.	1¾ O.D.	1¾	¾	31¼	17
D17 From Ser. No. 32001 thru Ser. No. 42000 (V)	22023	35335	1⅞	1½	4¼	18	13
COMBINE							
GAS							
A, B, C, H, R From Ser. No. 25301 (H)	22032	35793	2½	2⅞	4¼	19½	14¾
F Up to Ser. No. 12201 (H)							
G Up to Ser. No. 17001 (H)							
K (1968 and up) w/Chevrolet Eng.							
COMBINE							
DIESEL							
A2, C2 (H) F (all) 860 (Cotton Harvester)	22032	35793	2½	2⅞	4¼	19½	14¾

(V) Vertical

1 Fits Models w/172 Gas Eng. from 1953-57 and Models w/134 Gas Eng. from 1953 on.

2 Fits Models Up to 1964.

(H) Horizontal

3 Fits Models from 1964.

4 Fits Models from 1958-1964.

5 Requires 31322 Gasket.

● New Number

13 Requires 42596 Pipe.

14 Requires 41980 Adapter & 35753 Clamp.

TRACTOR

Models	Muffler No.	Inlet Clamp No.	Muffler Specs.				
			I.D. Inlet Dia.	O.D. Outlet Dia.	Shell Dia.	Overall Length	Shell Length

ALLIS-CHALMERS - Cont.

COMBINE LP	Muffler No.	Inlet Clamp No.	I.D. Inlet Dia.	O.D. Outlet Dia.	Shell Dia.	Overall Length	Shell Length
A, B, C, H, R From Ser. No. 25301 (H) F Up to Ser. No. 12201 (H) G Up to Ser. No. 17001 (H)	22032	35793	2½	2⅝	4¼	19½	14¾

DAVID BROWN

GAS							
780, 880 (V)	21039	35335	1 ¹⁵ / ₁₆	2	4 ⁵ / ₈	28 ³ / ₈	15 ⁹ / ₁₆
990, 1200 (V)	22042	35343	1¾ O.D.	1¾	3¼	31½	15½
885, 990, 995, 996, 1210, 1212 (H)	22110	35405	1⅝	1⅝ I.D.	4¼	22½	17⅝
	w/35250						
DIESEL							
780, 880 (V)	21039	35335	1 ¹⁵ / ₁₆	2	4 ⁵ / ₈	28 ³ / ₈	15 ⁹ / ₁₆
990, 1200 (V)	22042	35343	1¾ O.D.	1¾	3¼	31½	15½
885, 990, 995, 996, 1210, 1212 (H)	22110	35405	1⅝	1⅝ I.D.	4¼	22½	17⅝
	w/35250						

J.I. CASE

GAS							
C, CC, C1, D, DC, DC-4, DE, D1, D1M, DS, DV, TM, 400, 700 & 800 (V)	21033	35335	2¼	2¼	4¼	26¾	22½

- (V) Vertical
1 Fits Models w/172 Gas Eng. from 1953-57 and Models w/134 Gas Eng. from 1953 on.
2 Fits Models Up to 1964.

- (H) Horizontal
3 Fits Models from 1964.
4 Fits Models from 1958-1964.
5 Requires 31322 Gasket.

- New Number
13 Requires 42596 Pipe.
14 Requires 41980 Adapter & 35753 Clamp.

INFORMATION & BUILD TO ORDER

TOOLS AND ACCESSORIES

SCHOOL BUS

MEDIUM DUTY TRUCK GVV 3-6

HEAVY DUTY TRUCK GVV 7-8

APPLICATION BY ENGINE

NOISE AND BACKPRESSURE DATA

TRACTOR

MUFFLER SPECS

O.E. CROSS INDEX

TRACTOR

Models	Muffler No.	Inlet Clamp No.	Muffler Specs.				
			I.D. Inlet Dia.	O.D. Outlet Dia.	Shell Dia.	Overall Length	Shell Length

J.I. CASE - Cont.

GAS - Cont.							
VA, VAC, VAH, VAI, VAS, 300, 350, 500, VC 600, 310 Utility, 200B, 300B, 400B, 500B (V) VA Series, 200B, 300B, 400B, 500B	21039	35335	1 ⁵ / ₁₆	2	4 ⁵ / ₈	28 ³ / ₄	15 ⁹ / ₁₆
LCK-430G, 440, 441, 530, 630, 640, 641 (V)	21473	35337	2 ¹ / ₂	2 ⁵ / ₈	4 ⁵ / ₈	27 ³ / ₄	14
200B, 210B, 211B, Gas 430, 530 Gas Before Ser. No. 8191147, 300, 300B, 301B, 311B, 410B, 500B (H)	22110	35405	1 ⁵ / ₈	1 ⁵ / ₈ I.D.	4 ¹ / ₄	22 ¹ / ₂	17 ⁵ / ₈
600B, 610, 611B (V)	22109	35334	2 ¹ / ₈	1 ⁷ / ₈ I.D.	4 ¹ / ₄	21	15 ¹ / ₄
600B, 610B, and 611B (H)	22023	35335	1 ⁷ / ₈	1 ¹ / ₂	4 ¹ / ₄	18	13
430, 530 After Ser. No. 8191147, LCK-530D & 600 (H)	22109	35334	2 ¹ / ₈	1 ⁷ / ₈ I.D.	4 ¹ / ₄	21	15 ¹ / ₄
LA, 900, 930, 940, 1030, 1200 (V)	22037	35794	2 ³ / ₄	2 ¹ / ₂	4 ⁵ / ₈	26 ¹ / ₈	16 ¹ / ₂
730, 830 (Exc. Comfort King), 730C, 830C, 740, 840 (V)	21473	35337	2 ¹ / ₂	2 ⁵ / ₈	4 ⁵ / ₈	27 ³ / ₄	14
470, 480, 570, 580 (Back Hoe-Loader)	22390	35337	2 ¹ / ₂	1 ⁷ / ₈	4 ⁵ / ₈ x 8 ³ / ₈	33 ¹ / ₂	19
DIESEL							
C, CC, C1, D, DC, DC-4, DE, D1, D1M, DS, DV, TM, 400, 700, 800 (V)	21033	35335	2 ¹ / ₄	2 ¹ / ₄	4 ¹ / ₄	26 ³ / ₄	22 ¹ / ₂
430 Before Ser. No. 8262800 (1966), 431LCK-430D, LCK-430G, 440, 441, 530, 630, 640, 641 (V)	21473	35337	2 ¹ / ₂	2 ⁵ / ₈	4 ⁵ / ₈	27 ³ / ₄	14
200B, 210B, 211B, Gas 430, 530 Gas Before Ser. No. 8191147, 300, 300B, 301B, 311B, 410B, 500B (H)	22110	35405	1 ⁵ / ₈	1 ⁵ / ₈ I.D.	4 ¹ / ₄	22 ¹ / ₂	17 ⁵ / ₈
430, 530 Before Ser. No. 8262800, LCK-530D & 600 (H)	22109	35334	2 ¹ / ₈	1 ⁷ / ₈ I.D.	4 ¹ / ₄	21	15 ¹ / ₄
500, 600, 900, 930, 940, 1200 (V)	22037	35794	2 ³ / ₄	2 ¹ / ₂	4 ⁵ / ₈	26 ¹ / ₈	16 ¹ / ₂
1170, 1175, 1270, 1370 w/451 C.I.D. w/Turbocharger (V)	22861	35753	3 ¹ / ₂	3 ⁵ / ₈	5 ⁵ / ₈	42	28
730, 740, 830, 840 (V)	21473	35337	2 ¹ / ₂	2 ⁵ / ₈	4 ⁵ / ₈	27 ³ / ₄	14
470, 480, 570, 580	21473	35337	2 ¹ / ₂	2 ⁵ / ₈	4 ⁵ / ₈	27 ³ / ₄	14
COMBINE							
GAS & DIESEL							
700, 900, 960 (V)	21188	35335	2	2 ³ / ₁₆	4 ¹ / ₄	17	12 ¹ / ₁₆

(V) Vertical

1 Fits Models w/172 Gas Eng. from 1953-57 and Models w/134 Gas Eng. from 1953 on.

2 Fits Models Up to 1964.

(H) Horizontal

3 Fits Models from 1964.

4 Fits Models from 1958-1964.

5 Requires 31322 Gasket.

● New Number

13 Requires 42596 Pipe.

14 Requires 41980 Adapter & 35753 Clamp.

TRACTOR

Models	Muffler No.	Inlet Clamp No.	Muffler Specs.				
			I.D. Inlet Dia.	O.D. Outlet Dia.	Shell Dia.	Overall Length	Shell Length

INFORMATION & BUILD TO ORDER

COCKSHUTT

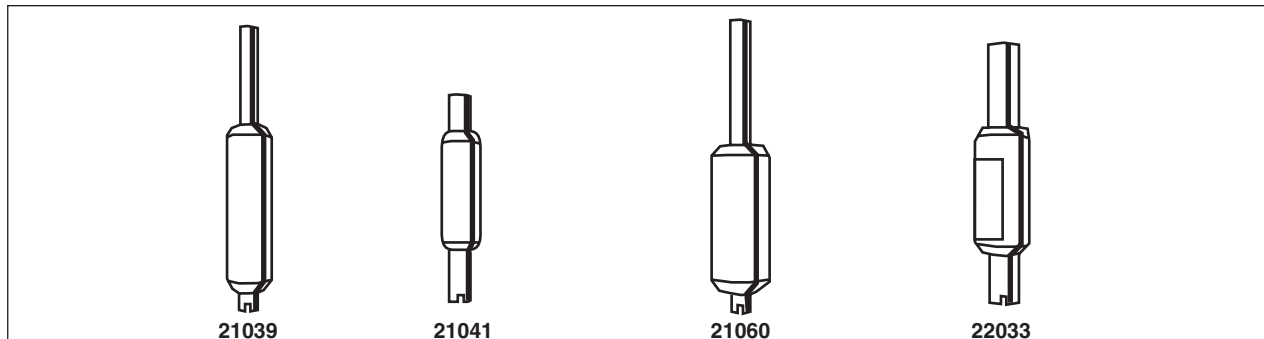

TOOLS AND ACCESSORIES

SCHOOL BUS

GAS								
30, R30 (V)	21039	35335	1 ¹⁵ / ₁₆	2	4 ⁵ / ₈	28 ³ / ₈	15 ⁹ / ₁₆	
40, R40, 50, 560, 570, R40, E4, E5 (V)	21060	35337	2 ³ / ₈	2 ¹ / ₂	5 ⁵ / ₈	32	17 ¹¹ / ₁₆	
1750, 1800, 1850 (V)	22033	35794	2 ⁷ / ₈	3	5 ⁵ / ₈	32 ¹ / ₂	21	
770 HC, D, G, 1600 HC, D, G, 1650G, 1550D, G	21041	35337	2 ¹³ / ₃₂	2 ¹ / ₂	4 ¹ / ₂	21	10 ⁷ / ₈	

MEDIUM DUTY TRUCK GVV 3-6

DIESEL								
1650, 1750, 1800, 1850 (V)	22033	35794	2 ⁷ / ₈	3	5 ⁵ / ₈	32 ¹ / ₂	21	

HEAVY DUTY TRUCK GVV 7-8

JOHN DEERE

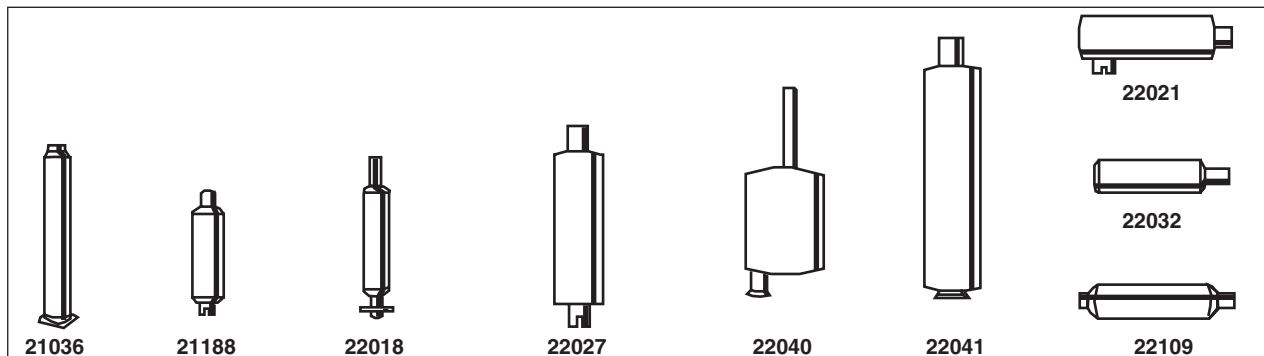

APPLICATION BY ENGINE

NOISE AND BACKPRESSURE DATA

GAS								
A, G, 60, 70, 620, 720 (V)	21036	N.R.	2 ¹ / ₂	2 ⁵ / ₁₆	3 ³ / ₄	20 ¹⁵ / ₁₆	19 ⁷ / ₈	
330, 420 After Ser. No. 135025, 430, 440 After Ser. No. 142886 (V)	21188	35335	2	2 ³ / ₁₆	4 ¹ / ₄	17	12 ¹¹ / ₁₆	
M, MT, M40, 320 (V)	22018	N.R.	1 ¹⁵ / ₁₆	1 ¹ / ₂	3 ¹ / ₄	20 ³ / ₈	13 ¹ / ₂	
1010 (V)	21188	35335	2	2 ³ / ₁₆	4 ¹ / ₄	17	12 ¹¹ / ₁₆	
3010, 3020, 4000 (V)	22027	35760	2 ²⁹ / ₃₂	2 ¹⁹ / ₃₂	6 ⁵ / ₈	27 ³ / ₈	21	
1020, 1520, 1530, 2020, 2030, 2040, 2240, 2440, 2510, 2520, 2630, 2640 (V)	22040 ⁵	N.A.	2 ¹³ / ₃₂	1 ²⁵ / ₃₂	4 ⁵ / ₈ x 8 ³ / ₈	32	19	
2010 (V)	22109	35334	2 ¹ / ₈	1 ⁷ / ₈ I.D.	4 ¹ / ₄	21	15 ¹ / ₄	
4010, 4020, 4230 (V)	22027	35760	2 ²⁹ / ₃₂	2 ¹⁹ / ₃₂	6 ⁵ / ₈	27 ³ / ₈	21	

LP GAS								
3010, 3020 (V)	22027	35760	2 ²⁹ / ₃₂	2 ¹⁹ / ₃₂	6 ⁵ / ₈	27 ³ / ₈	21	
2010 (V)	22109	35334	2 ¹ / ₈	1 ⁷ / ₈ I.D.	4 ¹ / ₄	21	15 ¹ / ₄	
4010, 4020, 4230 (V)	22027	35760	2 ²⁹ / ₃₂	2 ¹⁹ / ₃₂	6 ⁵ / ₈	27 ³ / ₈	21	

TRACTOR

MUFFLER SPECS

O.E. CROSS INDEX

- (V) Vertical
1 Fits Models w/172 Gas Eng. from 1953-57 and Models w/134 Gas Eng. from 1953 on.
2 Fits Models Up to 1964.

- (H) Horizontal
3 Fits Models from 1964.
4 Fits Models from 1958-1964.
5 Requires 31322 Gasket.

- New Number
13 Requires 42596 Pipe.
14 Requires 41980 Adapter & 35753 Clamp.

TRACTOR

Models	Muffler No.	Inlet Clamp No.	Muffler Specs.				
			I.D. Inlet Dia.	O.D. Outlet Dia.	Shell Dia.	Overall Length	Shell Length

JOHN DEERE - Cont.

DIESEL								
A, G, 60, 70, 620, 720 (V)	21036	N.R.	2½	2⅝	¾	20⅝	19⅞	
330, 420 After Ser. No. 135025, 430, 440 After Ser. No. 142886, 435 (V)	21188	35335	2	2⅜	¼	17	12⅞	
3010 Before Ser. No.16643, 4000 (V)	22027	35760	2 ²⁹ / ₃₂	2 ¹⁹ / ₃₂	⅝	27⅞	21	
820 Manheim, 830 Manheim, 1020, 1520, 1530, 2020, 2030, 2040, 2240, 2440, 2510, 2520, 2630, 2640 (V)	22040 ⁵	N.A.	2 ¹³ / ₃₂	1 ²⁵ / ₃₂	4⅝ x 8⅝	32	19	
1010, 2010 (V)	22109	35334	2⅞	1⅞ I.D.	¼	21	15¼	
4010 To Ser. No. 217026, 4020 Up to 1969 (V)	22027	35760	2 ²⁹ / ₃₂	2 ¹⁹ / ₃₂	⅝	27⅞	21	
4030, 4320, 4430, 4440, 4450, 4520, 4620, 4630, 4640, 5010, 5020, 5250, 7020 (V)	22041	N.A.	3 ²⁹ / ₃₂	3 ¹⁹ / ₃₂	4⅝ x 8⅝	38	33	
4520 Pipe (V)	42531	35752	4	4	24	—		
COMBINE								
GAS								
45 From Ser. No. 45-8432 thru 45-21500, 55 Ser. No. 55-46801 to 55-57000, 65 (pull type) From Ser. No. 65-11001 Cotton Picker No. 11601 and Up, Series 99 Self Propelled. (V)	22032	35793	2½	2⅞	¼	19½	14¾	
55, With HC217 & HE217 JD Motor Ser. No. 57001 thru 59282 and Up.	21473	35337	2½	2	4⅝	30	17	
95 Up to No. 9000 w/HB217 Eng., Ser. No. 9001-11540 w/HD217 Eng., Ser. No. 11541 & Up w/HG217 Eng., All 105 w/HA248 Eng. (V)	22021	35760	3 ⁵ / ₃₂	2¾	⅝	22½	19½	
699, 9900 Cotton Picker (H)	22021	35760	3 ⁵ / ₃₂	2¾	⅝	22½	19½	
COMBINE								
LP								
45 Ser. No. 45-8432 Up to 45-21500 w/HA145 Eng.	22032	35793	2½	2⅞	¼	19½	14¾	
COMBINE								
DIESEL								
45 Ser. No. Up to 25995 w/HA155 Eng., Ser. No. 25996 and Up w/HA165 Eng., 99 Self Propelled w/HA217 or NB217 Eng	22032	35793	2½	2⅞	¼	19½	14¾	
55 Ser. No. 46801 to 60000 w/HA232 Eng.	22021	35760	3 ⁵ / ₃₂	2¾	⅝	22½	19½	

(V) Vertical

1 Fits Models w/172 Gas Eng. from 1953-57 and Models w/134 Gas Eng. from 1953 on.

2 Fits Models Up to 1964.

(H) Horizontal

3 Fits Models from 1964.

4 Fits Models from 1958-1964.

5 Requires 31322 Gasket.

● New Number

13 Requires 42596 Pipe.

14 Requires 41980 Adapter & 35753 Clamp.

TRACTOR

Models	Muffler No.	Inlet Clamp No.	Muffler Specs.				
			I.D. Inlet Dia.	O.D. Outlet Dia.	Shell Dia.	Overall Length	Shell Length

FORD

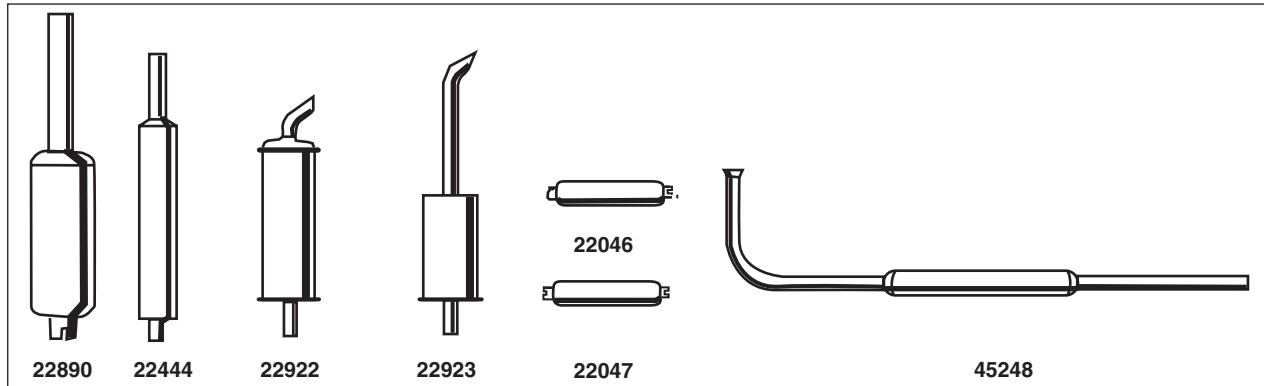

Models	Muffler No.	Inlet Clamp No.	I.D. Inlet Dia.	O.D. Outlet Dia.	Shell Dia.	Overall Length	Shell Length
GAS							
2N, 8N, 9N (H)	45248	N.A.	1½	1⅝	¾	53¾	24
NAA, 501, 600, 700, 800, 900 (H) & (V)	22046 ^{1,5,8}	35344	1 ²¹ / ₃₂	1½ I.D.	¾	17¾	15
2000, 4000 (H) & (V)	22046 ²	35344	1 ²¹ / ₃₂	1½ I.D.	¾	17¾	15
501, 600, 700, 800, 1801 (H)	22047 ⁴	35336	2	1¾ I.D.	¾	17¼	15
2000, 3000, 4000, 5000, 4400, 5100 (V) (1968 & Up)	22444	35335	1⅞	2	5⅝	28¾	17
7000, 7100, 7200, 7600, 7610, 7700, 7710 (V)	22890	35337	2⅜	2½	4⅞ x 9	49	26
DIESEL							
2000, 4000 (H) & (V)	22046 ²	35344	1 ²¹ / ₃₂	1½ I.D.	¾	17¾	15
501, 600, 700, 800, 900, 1801 (H) & (V)	22047 ⁴	35336	2	1¾ I.D.	¾	17¼	15
2000, 3000, 4000, 5000, 4400, 5100 (V) (1968 & Up)	22444	35335	1⅞	2	5⅝	28¾	17
7000, 7100, 7200, 7600, 7610, 7700, 7710 (V)	22890	35337	2⅜	2½	4⅞ x 9	49	26
(1981-85) 2910, 3910, 4110 (V) (1981-82) 531, 4610 (V) (1978-82) 545 (V) (1976) 515, 531, 535, 4000, 4100, 4600, 5600, 5700, 6600, 6700 w/Cab. (V)	22922	35344	1⅞	2 Spout	4⅞	40¾	26
(1985) 2810, 2910, 3910 (V) (1981-82) 230-A, 2610, 3610 (V) (1978-87) 340, 445, 540 (V) (1975) 231, 335, 420, 2600, 3600 (V) (1965) 2000, 3000	22923	35344	1⅞	2 Spout	4⅞ x 9	48⅝	18

INTERNATIONAL HARVESTER & FARMALL

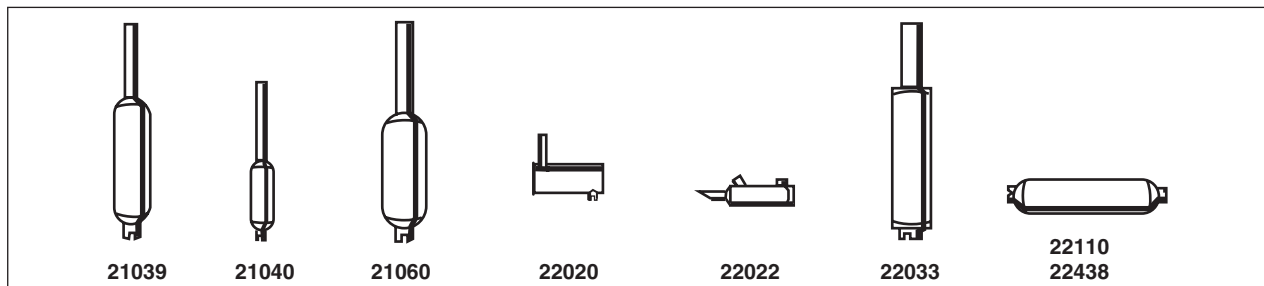

Models	Muffler No.	Inlet Clamp No.	I.D. Inlet Dia.	O.D. Outlet Dia.	Shell Dia.	Overall Length	Shell Length
Cub, Cub Lo-Boy	21040	35324	1 ¹¹ / ₃₂	1⅞	¾	22	9⅝

- (V) Vertical
1 Fits Models w/172 Gas Eng. from 1953-57 and Models w/134 Gas Eng. from 1953 on.
2 Fits Models Up to 1964.

- (H) Horizontal
3 Fits Models from 1964.
4 Fits Models from 1958-1964.
5 Requires 31322 Gasket.

- New Number
13 Requires 42596 Pipe.
14 Requires 41980 Adapter & 35753 Clamp.

TRACTOR

Models	Muffler No.	Inlet Clamp No.	Muffler Specs.				
			I.D. Inlet Dia.	O.D. Outlet Dia.	Shell Dia.	Overall Length	Shell Length

INTERNATIONAL HARVESTER & FARMALL - Cont.

GAS - Cont.							
A, Super A, AV, Super AV, A-1, B, BN, C, Super C, 100, 130, 140, 200, 230, 240, 330, 340, 404 Series (V)	21039	35335	1 ¹⁵ / ₁₆	2	4 ⁵ / ₈	28 ³ / ₈	15 ⁹ / ₁₆
H, Super H, HV, Super HV, M, Super M, Super MTA, W4, Super W4, W6, Super W6, WD6, Super WD6, W6TA, 300, 350, 400, 450, 454, 464, 544, 574, 606, 664, 674 (V)	21060	35337	2 ³ / ₈	2 ¹ / ₂	5 ⁵ / ₈	32	17 ¹¹ / ₁₆
300, 330, 340, 350, 504 w/153 C.I.D. (V)	22110	35405	1 ⁵ / ₈	1 ⁵ / ₈ I.D.	4 ¹ / ₄	22 ¹ / ₂	17 ⁵ / ₈
I.H. 300, Ser. No. 9501 thru 62482. Farmall 300 Ser. No. 62482 and Up. I.H. 350 Ser. No. 501 and Up. Series 504 Ser. No. 3104 and Up. (H)	22110	35405	1 ⁵ / ₈	1 ⁵ / ₈ I.D.	4 ¹ / ₄	22 ¹ / ₂	17 ⁵ / ₈
460, 560, 656, 660 Series (V)	21060	35337	2 ³ / ₈	2 ¹ / ₂	5 ⁵ / ₈	32	17 ¹¹ / ₁₆
I.H. 460, 560, 460 Grove, 660, 606, Farmall 460	22438	35335	1 ⁷ / ₈	1 ⁷ / ₈	4 ¹ / ₄	22 ¹ / ₂	—
I.H. 504, 424, 3444, 2424, 444, 2444, 2504, 2500, 3414	21039	35335	1 ¹⁵ / ₁₆	2	4 ⁵ / ₈	28 ³ / ₈	15 ⁹ / ₁₆
706, 756, 806, 826, 856 (V)	22033	35794	2 ²⁹ / ₃₂	3	5 ¹ / ₄	32 ¹ / ₂	21 ³ / ₁₆
DIESEL							
A, Super A, AV, Super AV, A-1, B, BN, C, Super C, 100, 130, 140, 200, 230, 240, 330, 404 Series (V)	21039	35335	1 ¹⁵ / ₁₆	2	4 ⁵ / ₈	28 ³ / ₈	15 ⁹ / ₁₆
H, Super H, HV, Super HV, M, Super M, Super MTA, W4, Super W4, W6, Super W6, MV, MD, MDV, WD6, Super WD6, W6TA, 300, 340, 350, 400, 450, 454, 460, 464, 504, 544, 560, 574, 606, 656, 660, 664, 674, 706 (V)	21060	35337	2 ³ / ₈	2 ¹ / ₂	5 ⁵ / ₈	32	17 ¹¹ / ₁₆
300, 330, 350, w/188 C.I.D. (V)	22110	35405	1 ⁵ / ₈	1 ⁵ / ₈ I.D.	4 ¹ / ₄	22 ¹ / ₂	17 ⁵ / ₈
I.H. 460, 560, 460 Grove, 660, 606, Farmall 460, I.H. 504 (H)	22438	35335	1 ⁷ / ₈	1 ⁷ / ₈	4 ¹ / ₄	22 ¹ / ₂	—
I.H. 424, 2424, 444, 2444	21039	35335	1 ¹⁵ / ₁₆	2	4 ⁵ / ₈	28 ³ / ₈	15 ⁹ / ₁₆
706, 756, 806, 826, 856 (V)	22033	35794	2 ²⁹ / ₃₂	3	5 ¹ / ₄	32 ¹ / ₂	21 ³ / ₁₆
LP							
A, Super A, AV, Super AV, A-1, B, BN, C, Super C, 100, 130, 140, 200, 230, 240, 330, 404 Series (V)	21039	35335	1 ¹⁵ / ₁₆	2	4 ⁵ / ₈	28 ³ / ₈	15 ⁹ / ₁₆
H, Super H, HV, Super HV, M, Super M, Super MTA, W4, Super W4, W6, Super W6, WD6, Super WD6, W6TA, 300, 350, 400, 450, 454, 464, 544, 574, 606, 664, 674 (V)	21060	35337	2 ³ / ₈	2 ¹ / ₂	5 ⁵ / ₈	32	17 ¹¹ / ₁₆
300, 330, 340, 350, 504 w/153 C.I.D. (V)	22110	35405	1 ⁵ / ₈	1 ⁵ / ₈ I.D.	4 ¹ / ₄	22 ¹ / ₂	17 ⁵ / ₈
450, 560, 656, 660 Series (V)	21060	35337	2 ³ / ₈	2 ¹ / ₂	5 ⁵ / ₈	32	17 ¹¹ / ₁₆
706, 756, 806, 826, 856 (V)	22033	35794	2 ²⁹ / ₃₂	3	5 ¹ / ₄	32 ¹ / ₂	21 ³ / ₁₆
COMBINE GAS							
303 w/C221 Eng. Cotton Pickers - 414, 420 w/C263 Eng. (V)	21060	35337	2 ³ / ₈	2 ¹ / ₂	5 ⁵ / ₈	32	17 ¹¹ / ₁₆
205, 315, 403 Gas Hydro, 403 Hillside w/C282 Eng., Ser. No. 5001 & Up. 503 (V)	22033	35794	2 ²⁹ / ₃₂	3	5 ¹ / ₄	32 ¹ / ₂	21
315, 403 w/D301 Eng., Ser. No. 7224 & Up, 403 Hillside w/D301 Eng., Ser. No. 641 & Up 453 Hillside w/D301 Eng., 503, 615, 715, 422 w/D282 Eng. (V)	21060	35337	2 ³ / ₈	2 ¹ / ₂	5 ⁵ / ₈	32	17 ¹¹ / ₁₆

(V) Vertical

1 Fits Models w/172 Gas Eng. from 1953-57 and Models w/134 Gas Eng. from 1953 on.

2 Fits Models Up to 1964.

(H) Horizontal

3 Fits Models from 1964.

4 Fits Models from 1958-1964.

5 Requires 31322 Gasket.

● New Number

13 Requires 42596 Pipe.

14 Requires 41980 Adapter & 35753 Clamp.





TRACTOR

Models	Muffler No.	Inlet Clamp No.	Muffler Specs.				
			I.D. Inlet Dia.	O.D. Outlet Dia.	Shell Dia.	Overall Length	Shell Length

INTERNATIONAL HARVESTER & FARMALL — Cont.

GARDEN TRACTOR							
GAS							
102, 104, 105, 106, 107, 108, 109, 122, 123, 124, 125, 126, 127, 128, 129, 147, 149 (H)	22022	35325	1 ¹¹ / ₃₂	1 ³ / ₈	3 ¹ / ₄	15 ³ / ₄	11
1000, 1250, 1450, 1650 (H)	22020	35405	1 ⁷ / ₁₆	1 ³ / ₈	5	12 ¹ / ₂	12 ¹ / ₂

MASSEY-FERFUSON

								
21035	21041	22023	22024	22035				
GAS								
MF-135 (H)	21035	35325	1 ¹ / ₂	1 ⁵ / ₈	3 ¹ / ₄	34 ¹ / ₄	24	
MF-135 (V)	22023	35335	1 ⁷ / ₈	1 ¹ / ₂	4 ¹ / ₄	18	13	
20, 20K, 22, 22K, 30, 30K, 33, 333, 44, 44K, 44D, 44-6, 44 Special, 444, 55, 55K, 55D, 555, 81, 82, 101 Jr., 101 Senior, 102 Jr., 102 Senior (1942-1957) (V)	21041	35337	2 ¹³ / ₃₂	2 ¹ / ₂	4 ¹ / ₂	21	10 ⁷ / ₈	
TO35, MH35, MF35 (H)	21035	35325	1 ¹ / ₂	1 ⁵ / ₈	3 ¹ / ₄	34 ¹ / ₄	24	
MF-35 Utility, MF202, MF-203, MF204, MF205 (V)	22023	35335	1 ⁷ / ₈	1 ¹ / ₂	4 ¹ / ₄	18	13	
F-40, M11-50, MF-50 (H)	22024	35335	1 ²⁹ / ₃₂	1 ³ / ₈	3 ¹ / ₄	18 ¹ / ₂	17 ³ / ₈	
MF-65 (H)	22035	35335	1 ²⁹ / ₃₂	1 ¹¹ / ₃₂	3 ¹ / ₄	18	15	
DIESEL								
MF-135 (H)	21035	35325	1 ¹ / ₂	1 ⁵ / ₈	3 ¹ / ₄	34 ¹ / ₄	24	
MF-135 (V)	22023	35335	1 ⁷ / ₈	1 ¹ / ₂	4 ¹ / ₄	18	13	
(1942-1957) 20, 20K, 22, 22K, 30, 30K, 33, 333, 44, 44K, 44D, 44-6, 44 Special, 444, 55, 55K, 55D, 555, 81, 82, 101 Jr., 101 Senior, 102 Jr., 102 Senior (V)	21041	35337	2 ¹³ / ₃₂	2 ¹ / ₂	4 ¹ / ₂	21	10 ⁷ / ₈	
TO-20, TO-30 w/Perkins Eng., TO-35, MN-35, MF-35 (H)	21035	35325	1 ¹ / ₂	1 ⁵ / ₈	3 ¹ / ₄	34 ¹ / ₄	24	
LP								
(1942-1957) 20, 20K, 22, 22K, 30, 30K, 33, 333, 44, 44K, 44D, 44-6, 44 Special, 444, 55, 55K, 55D, 555, 81, 82, 101 Jr., 101 Senior, 102 Jr., 102 Senior (V)	21041	35337	2 ¹³ / ₃₂	2 ¹ / ₂	4 ¹ / ₂	21	10 ⁷ / ₈	
F-40, MH50, MF-50 (H)	22024	35335	1 ²⁹ / ₃₂	1 ³ / ₈	3 ¹ / ₄	18 ¹ / ₂	17 ³ / ₈	

- (V) Vertical
1 Fits Models w/172 Gas Eng. from 1953-57 and Models w/134 Gas Eng. from 1953 on.
2 Fits Models Up to 1964.

- (H) Horizontal
3 Fits Models from 1964.
4 Fits Models from 1958-1964.
5 Requires 31322 Gasket.

- New Number
13 Requires 42596 Pipe.
14 Requires 41980 Adapter & 35753 Clamp.

INFORMATION & BUILD TO ORDER

TOOLS AND ACCESSORIES

SCHOOL BUS

MEDIUM DUTY TRUCK GVV 3-6

HEAVY DUTY TRUCK GVV 7-8

APPLICATION BY ENGINE

NOISE AND BACKPRESSURE DATA

TRACTOR



MUFFLER SPECS

O.E. CROSS INDEX



TRACTOR

Models	Muffler No.	Inlet Clamp No.	Muffler Specs.				
			I.D. Inlet Dia.	O.D. Outlet Dia.	Shell Dia.	Overall Length	Shell Length

MINNEAPOLIS-MOLINE

								
22037		22038						
GAS								
335 Universal & Utility, 445 Universal & Utility (V)	22038	35337	2 ⁹ / ₃₂	2 ¹¹ / ₃₂	4 ¹ / ₄	17 ¹ / ₈	13	
Old Model Z.G. U66 (GV1), 5 Star, Jet Star (V)	22037	35794	2 ³ / ₄	2 ¹ / ₂	4 ⁵ / ₈	26 ¹ / ₈	16 ¹ / ₂	
DIESEL								
445 Universal & Utility (V)	22038	—	2 ⁹ / ₃₂	2 ¹¹ / ₃₂	4 ¹ / ₄	17 ¹ / ₈	13	
Old Model Z.G. U66 (GV1), 5 Star, Jet Star (V)	22037	35794	2 ³ / ₄	2 ¹ / ₂	4 ⁵ / ₈	26 ¹ / ₈	16 ¹ / ₂	

OLIVER

								
22033		22039						
GAS								
66 (V)	22039	35793	2 ¹³ / ₃₂	1 ²⁵ / ₃₂	6 ⁵ / ₈	10 ³ / ₈	5 ¹ / ₂	
1750, 1800, 1850 (V)	22033	35794	2 ⁷ / ₈	3	5 ⁵ / ₈	32 ¹ / ₂	21	
77 Ser. No. 320000 thru 326502, 77 HC (V)	22039	35793	2 ¹³ / ₃₂	1 ²⁵ / ₃₂	6 ⁵ / ₈	10 ³ / ₈	5 ¹ / ₂	
DIESEL								
66 (V)	22039	—	2 ¹³ / ₃₂	1 ²⁵ / ₃₂	6 ⁵ / ₈	10 ³ / ₈	5 ¹ / ₂	
1650, 1750, 1800, 1850 (V)	22033	35794	2 ⁷ / ₈	3	5 ⁵ / ₈	32 ¹ / ₂	21	
77 Ser. No. 320000 thru 326502, 77 HC, 88 (V)	22039	35793	2 ¹³ / ₃₂	1 ²⁵ / ₃₂	6 ⁵ / ₈	10 ³ / ₈	5 ¹ / ₂	

(V) Vertical

1 Fits Models w/172 Gas Eng. from 1953-57 and Models w/134 Gas Eng. from 1953 on.

2 Fits Models Up to 1964.

(H) Horizontal

3 Fits Models from 1964.

4 Fits Models from 1958-1964.

5 Requires 31322 Gasket.

● New Number

13 Requires 42596 Pipe.

14 Requires 41980 Adapter & 35753 Clamp.

TRACTOR

Models	Muffler No.	Inlet Clamp No.	Muffler Specs.				
			I.D. Inlet Dia.	O.D. Outlet Dia.	Shell Dia.	Overall Length	Shell Length

VERSATILE

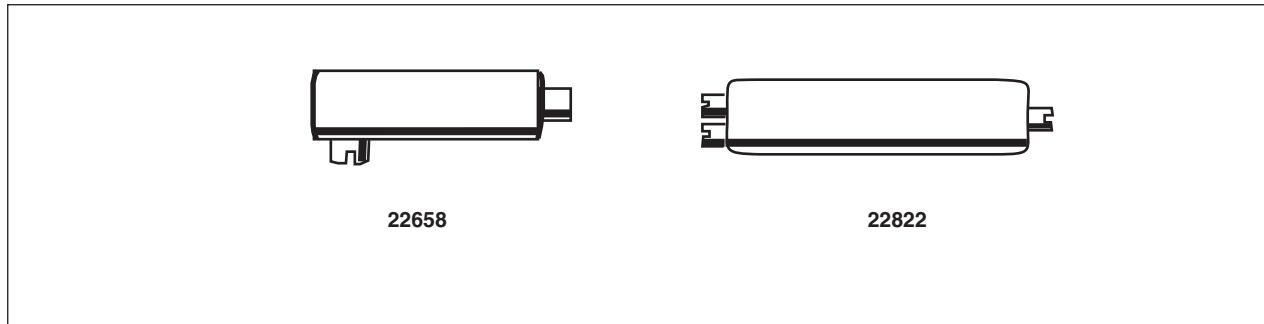

DIESEL							
118, 145 (V)	22822 (2)	35337	2½ Dual Inlet	3	8½	43	38
118, 145 (V)	22822 (2)	35337	2½ Dual Inlet	3	8½	43	38
(1981—Up) 400 Swather, 4400 Swather (Gas)	22658	35335	2	2⅛	5⅝	26	22½

- INFORMATION & BUILD TO ORDER
- TOOLS AND ACCESSORIES
- SCHOOL BUS
- MEDIUM DUTY TRUCK GVV 3-6
- HEAVY DUTY TRUCK GVV 7-8
- APPLICATION BY ENGINE
- NOISE AND BACKPRESSURE DATA
- TRACTOR
- MUFFLER SPECS
- O.E. CROSS INDEX

- (V) Vertical
- 1 Fits Models w/172 Gas Eng. from 1953-57 and Models w/134 Gas Eng. from 1953 on.
- 2 Fits Models Up to 1964.

- (H) Horizontal
- 3 Fits Models from 1964.
- 4 Fits Models from 1958-1964.
- 5 Requires 31322 Gasket.

- New Number
- 13 Requires 42596 Pipe.
- 14 Requires 41980 Adapter & 35753 Clamp.