

# STYLE 9

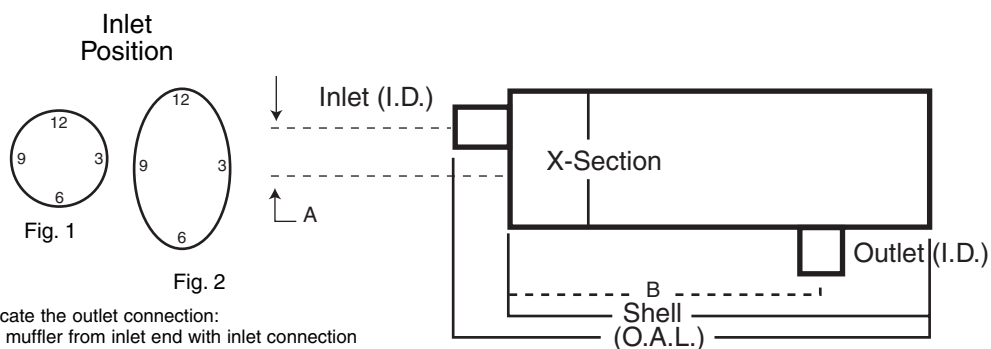

To locate the outlet connection:  
View muffler from inlet end with inlet connection near 12 o'clock. Outlet will be located clockwise from inlet per chart.

Inlet ID	Part No.	Cross Section	Shell Length	Overall Length	Outlet ID	"A" Inlet Offset	"B" Outlet Offset	Fig.	Inlet Position	Outlet Position
3 1/2	22391	8 1/4 x 11 1/2	28	31	4 OD	2 1/2	12	2	12	4
3 1/2	22214	8 1/4 x 11 1/2	26	30	4	2 1/2	14 3/4	2	12	10
3 1/2	21074	8 1/4 x 11 1/2	31 1/2	34 3/4	4 OD	2 1/2	7 1/8	2	12	4
3 1/2	21073	8 1/4 x 11 1/2	32	34 3/4	4 OD	2 1/2	21 1/4	2	12	4
3 1/2	22604	8 1/4 x 11 1/2	32	35	4	2 1/2	11 7/8	2	12	10
4	21968	10 1/8	27 3/4	31	4	2 1/2	3 1/2	1	12	8
4	21969	10	28	31 1/2	4	2 1/2	20 1/2	1	12	5
4	21970	10	36	39	4	2 1/2	30 1/2	1	12	6
4	22664	11	36	39	4	1 1/2	7 1/2	1	12	6
4	22668	11	36	39	4	2 1/2	3 7/8	1	12	1
4	22669	11	36	38 1/2	4	2 1/2	4 3/8	1	12	10
4	22006	8 1/4 x 11 1/2	28	31	4	2 1/2	12	2	12	8
4	22785	10 x 15	15	19 1/4	4	4 1/4	4	2	12	12
4	22786	10 x 15	22	25	4	4 1/4	14 5/8	2	12	6
4	21149	10 x 15	25 1/2	29 1/2	4 OD	5	4 1/2	2	12	6
4	22665	10 x 15	30	33	4	3 3/4	7 1/2	2	12	6
4	22555	10 x 15	36	39	4	3 3/4	7 1/2	2	12	6
4	22919	10 x 15	44 1/8	47 3/4	4	4 1/4	6	2	12	6
5	22596	9 x 14	18 1/2	22	5	3 7/8	14 1/2	2	12	6
5 OD	22666	10 x 15	34	38	5	3 1/2	5	2	12	6
5	22337	10 x 15	35 1/2	38 1/2	5	3 3/4	7 1/2	2	12	6
5	21165	11	36	39	5	2 1/2	7 1/2	1	12	6
5 OD	22950	12	36	40	5 OD	—	21 1/2	1	—	—